

EAW Series Air Preparation Unit

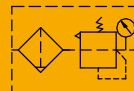

EAW2000 EAW3000 EAW4000

Filter Regulator



Specifications

Model	EAW2000-01	EAW2000-02	EAW3000-02	EAW3000-03	EAW3000-04	EAW4000-03	EAW4000-04	EAW4000-06
Working Medium	Clean Air(after 40 μ m filtration)							
Proof Pressure(MPa)	1.5							
Working Pressure Range(MPa)	0.15-1.0							
Pressure Adjustment Range(MPa)	0.05-0.9,Low pressure type 0.05-0.4							
Working Temperature(°C)	-5-60 (No freezing)							
Filter Precision	40 μ m/5 μ m optional							
Recommended Oil	Turbine No.1 Oil, ISO VG32							
Container Material	PC(Polycarbonate)							
Water Bowl Capacity(CC)	11		40			75		
Weight(g)	197		477			853		

How to Order?

Series No.	Port Size	Drain Type	Type No.	Pressure Gauge	Pressure Gauge Type	Bracket Code	Scale Unit	Filter Precision	Thread Type
EAW2000:EA2000 series Filter regulator		Blank: Manual drain type① C: Semi-anto drain D: Auto Drain type		Blank: With pressure gauge N: No pressure gauge		Blank: With bracket J: No bracket	③	Blank: 40 μ m 5M: 5 μ m	Blank: G P : PT T : NPT
EAW3000:EA3000 series Filter regulator							Square pressure gauge optional Round pressure gauge optional	1: MPa 2: Bar 3: Psi 4: Mpa/Psi 5: Bar/Psi	
EAW4000:EA4000 series Filter regulator	2000 ----- 02: 1/4" 3000 ----- 03: 3/8" 04: 1/2" 4000 ----- 03: 3/8" 04: 1/2" 06: 3/4"		Blank: Standard type	F:Square pressure gauge Y:Round pressure gauge②					

Order Example:

EA series FR unit, port size of 1/2", differential pressure drain type, with square pressure gauge, with bracket, Mpa, 5 μ m, G thread, the ERP code is: EAW3000-04CF15M

Remark: ①2000 series is only optional for manual drain type;

② Port of round pressure gauge is M6;It is not allowed to distribute pressure gauges to customers;

③ Square pressure gauge is single scale, round pressure gauge is double scale.

EAW Series Air Preparation Unit



Internal Structure

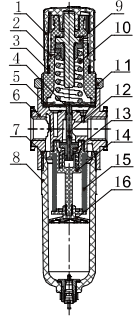

No.	Part Name	Material
1	Pressure regulating handle	Plastics
2	Pressure regulating valve cover	Plastics
3	Marking ring	Plastics
4	Diaphragm	SUS304+NBR
5	Gaskets	6061
6	Valve body	Aluminum alloy
7	Seal	NBR
8	Water bowl	Plastics
9	Protection guard	Plastics
10	Pressure regulating screw/Screw set	Free-cutting steel
11	Spring	SWC
12	Octagonal caps	Aluminum alloy
13	Spring	SUS304
14	Water separator propeller	Plastics
15	Valve core	Plastics
16	Water baffle	Plastics

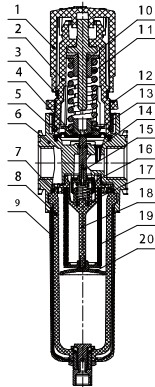

No.	Part Name	Material
1	Pressure regulating handle	Plastics
2	Pressure regulating valve cover	Plastics
3	Marking ring	Plastics
4	Pressure regulating spring seat	Plastics
5	Cover plate	Plastics
6	Valve body	Aluminum alloy
7	Seal	NBR
8	Water bowl	Plastics
9	Protection guard	Plastics
10	Pressure regulating screw/Screw set	Free-cutting steel
11	Spring	SWC
12	Octagonal caps	POM with glass fiber/Zinc alloy
13	Diaphragm	NBR
14	Interline	Plastics
15	Valve stem	Brass
16	Valve core	6061+NBR
17	Spring	SUS304
18	Water separator propeller	Plastics
19	Filter element	Plastics
20	Water baffle	Plastics

Pressure Feature

EAW2000

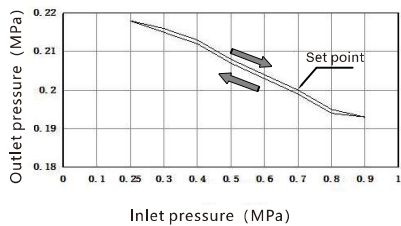

EAW3000

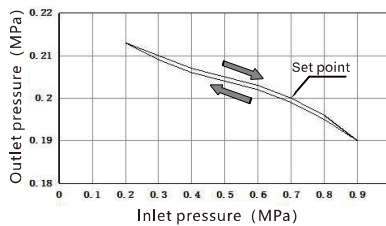

EAW4000

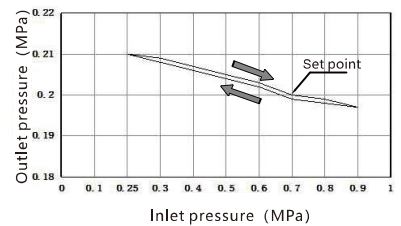

Flow Chart

EAW2000

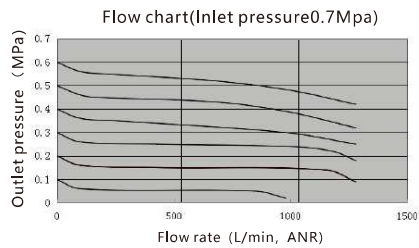

EAW3000

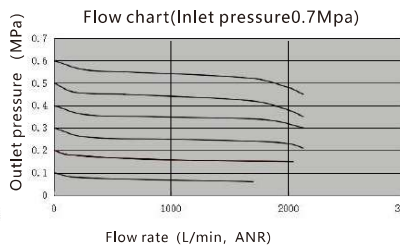

EAW4000

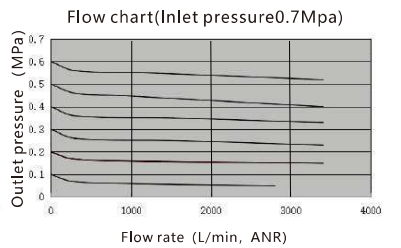

Main Dimensions

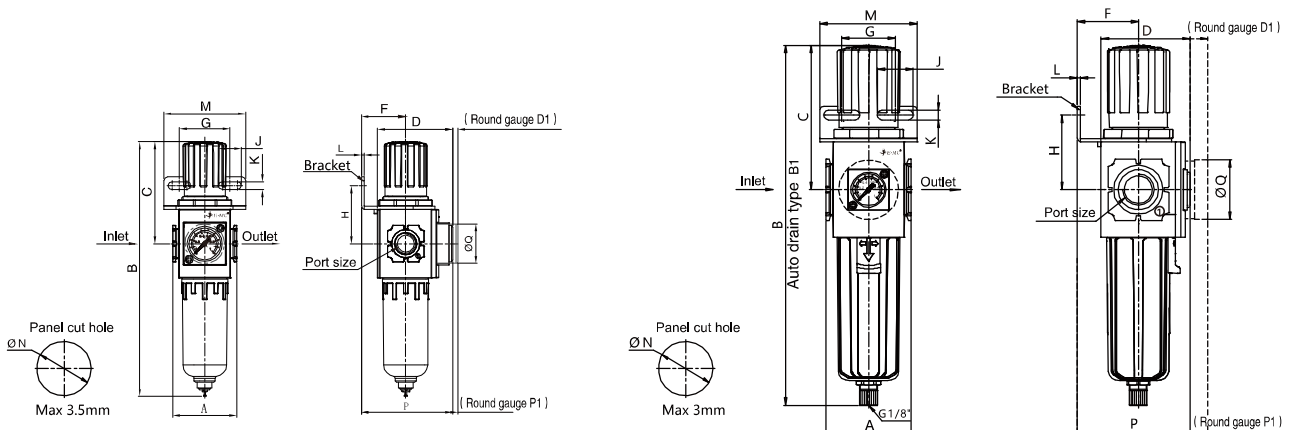

Model	Port Size	A	B	B1	C	D	D1	F	G	H	J	K	L	M	N	P	P1	Q
EAW 2000	1/8", 1/4"	43	171.2	-	68.6	50.6	54	30	34	39	15.5	5.5	2	55	31.5	61.6	65	26.5
EAW 3000	1/4", 3/8", 1/2"	57	239.6	236.6	96.6	61.6	73.3	41	36	50	24	6.5	2	65	36.5	75.8	87.5	40
EAW 4000	3/8", 1/2", 3/4"	80	270.2	264.5	105.4	81.8	93.5	50	38	53	28	8.5	2.5	72	52.5	95	106.7	40

4
EAW3000