

H Series Hand Push Valve (3/2,5/2,5/3 way)

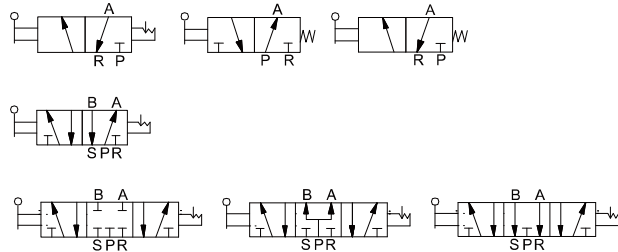

H

Hand Push Valve (3/2,5/2,5/3)



How to Order?

| Series No. | Ways | Positions | Valve Body Size | Original Status | Port Size | Reset | Thread Type |
|------------|----------------------|--------------------------------|--|--|--------------------------------|--|--|
| H | 3:3 ways 5:5 ways | 2:2 positions 3:3 positions | 1: 1 Series 2: 2 Series 3: 3 Series 4: 4 Series | C: Center close P: Center pressure E: Center exhaust (Only for 5/3 way) | 1 Series M5: M5 06: 1/8" | 3 Series 08: 1/4" 10: 3/8" 4 Series 06: 1/8" 10: 3/8" 15: 1/2" | Blank: Manual reset S: Spring return Blank: G P: PT T: NPT |

Order Example:

H series hand push valve, 3/2 way, 2 series valve body, NC type, 1/4" port size, manual reset, black valve body, G thread, ERP code is: H322-08

Remarks: Manual reset of two position tee can be divided into non opening and non closing

Specifications

| Model | H Series Hand push valve |
|---------------------------|-----------------------------------|
| Working medium | Clean air(After 40 μm filtration) |
| Acting type | External control |
| Lubrication | Not required |
| Working pressure(MPa) | 0~0.8 |
| Guaranteed pressure (MPa) | 1.2 |
| Working temperature (°C) | -5~60 |
| Seal material | NBR |

Product Features

- * Manual operated
- * Various working style are available

Main Dimension

H321/H322/H323/H324

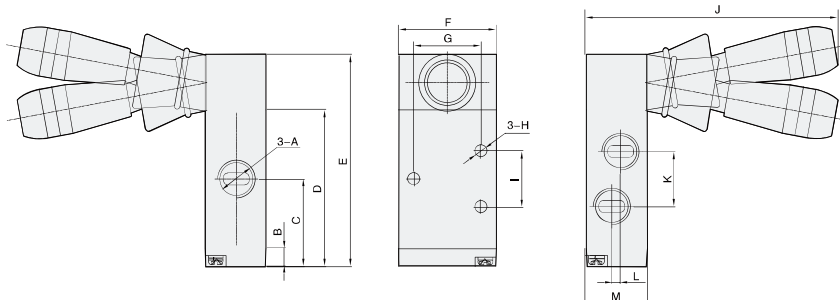

| Model/Sign | A | B | C | D | E | F | G | H | I | J | K | L | M |
|------------|------|-----|------|------|------|----|----|------|----|-------|------|---|----|
| H321-06 | G1/8 | 6.7 | 23.7 | 38.7 | 58.7 | 27 | 19 | Φ3.1 | 14 | 83.8 | 16 | 2 | 18 |
| H322-08 | G1/4 | 6.7 | 28.7 | 48.7 | 68.7 | 35 | 24 | Φ4.3 | 20 | 89 | 22.5 | 0 | 22 |
| H323-10 | G3/8 | 7.5 | 32.5 | 57.5 | 77.7 | 40 | 28 | Φ4.3 | 24 | 99.3 | 24 | 2 | 27 |
| H324-15 | G1/2 | 10 | 45 | 80 | 108 | 50 | 36 | Φ5.5 | 28 | 105.8 | 31.5 | 0 | 34 |

H Series Hand Push Valve (3/2,5/2,5/3 way)



◎ Main Dimension

H521/H522/H523/H524

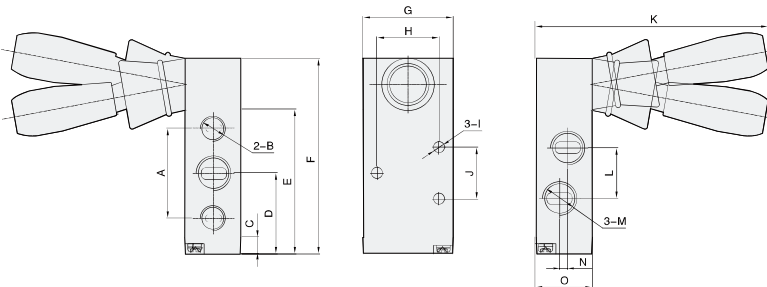

| Model/Sign | A | B | C | D | E | F | G | H | I | J | K | L | M | N | O |
|------------|----|------|-----|------|------|------|----|----|------|----|------|----|------|---|----|
| H521-06 | 28 | G1/8 | 6.7 | 28.2 | 49.7 | 69.7 | 27 | 19 | Φ3.3 | 14 | 83.8 | 16 | G1/8 | 3 | 18 |
| H522-08 | 35 | G1/8 | 6.7 | 31.7 | 56.7 | 76.7 | 35 | 24 | Φ4.3 | 20 | 91.3 | 20 | G1/4 | 3 | 22 |
| H523-10 | 45 | G1/4 | 7.5 | 40 | 72.5 | 92.5 | 40 | 28 | Φ4.3 | 24 | 96.5 | 24 | G3/8 | 4 | 27 |
| H524-15 | 63 | G1/2 | 10 | 57 | 104 | 132 | 50 | 36 | Φ5.5 | 28 | 105 | 36 | G1/2 | 4 | 34 |

H521-06S / H522-08S / H523-10S / H524-15S

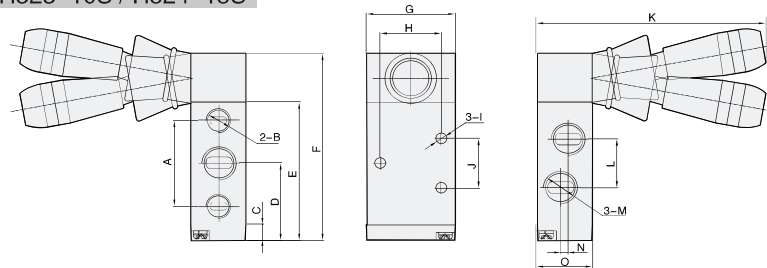

| Model/Sign | A | B | C | D | E | F | G | H | I | J | K | L | M | N | O |
|------------|----|------|-----|------|------|------|----|----|------|----|------|----|------|---|----|
| H521-06S | 28 | G1/8 | 6.7 | 28.2 | 49.7 | 69.7 | 27 | 19 | Φ3.3 | 14 | 87.5 | 16 | G1/8 | 3 | 18 |
| H522-08S | 35 | G1/8 | 6.7 | 31.7 | 56.7 | 76.7 | 35 | 24 | Φ4.3 | 20 | 90 | 20 | G1/4 | 3 | 22 |
| H523-10S | 45 | G1/4 | 7.5 | 40 | 72.5 | 92.5 | 40 | 28 | Φ4.3 | 24 | 96.5 | 24 | G3/8 | 4 | 27 |
| H524-15S | 63 | G1/2 | 10 | 57 | 104 | 132 | 50 | 36 | Φ5.5 | 28 | 105 | 36 | G1/2 | 4 | 34 |

H531-06S / H532-08S / H533-10S / H534-15S

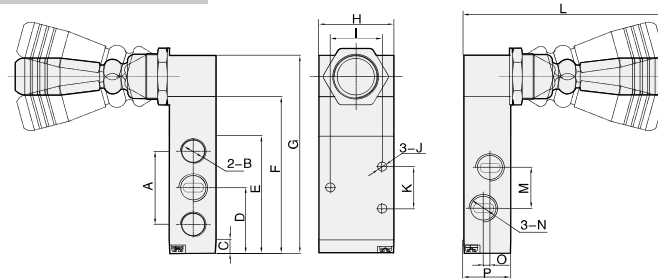

| Model/Sign | A | B | C | D | E | F | G | H | I | J | K | L | M | N | O | P |
|------------|----|------|-----|------|------|------|-------|----|----|------|----|-------|----|------|---|----|
| H531-06S | 28 | G1/8 | 6.5 | 28.2 | 49.7 | 64.5 | 84.7 | 27 | 19 | Φ3.3 | 14 | 92.5 | 16 | G1/8 | 3 | 18 |
| H532-08S | 35 | G1/8 | 6.5 | 31.7 | 56.7 | 75.5 | 97.7 | 35 | 24 | Φ4.3 | 20 | 94.2 | 20 | G1/4 | 3 | 22 |
| H533-10S | 45 | G1/4 | 7.5 | 40 | 72.5 | 91.5 | 113.5 | 40 | 28 | Φ4.3 | 24 | 100 | 24 | G3/8 | 4 | 27 |
| H534-15S | 63 | G1/2 | 10 | 57 | 104 | 124 | 154 | 50 | 36 | Φ5.5 | 28 | 109.6 | 36 | G1/2 | 4 | 34 |

H531-06C / H532-08C / H533-10C / H534-15C

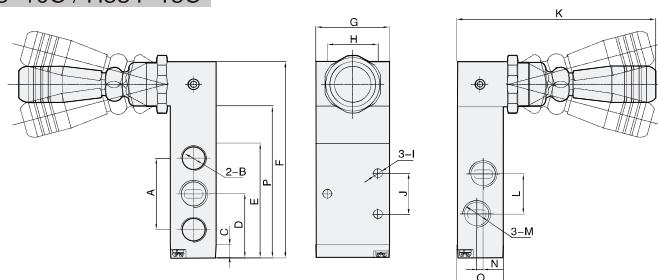

| Model/Sign | A | B | C | D | E | F | G | H | I | J | K | L | M | N | O | P |
|------------|----|------|-----|------|------|-------|----|----|------|----|------|----|------|---|----|------|
| H531-06C | 28 | G1/8 | 6.5 | 28.2 | 49.7 | 84.5 | 27 | 19 | Φ3.3 | 14 | 94.5 | 16 | G1/8 | 3 | 18 | 64.5 |
| H532-08C | 35 | G1/8 | 6.5 | 31.7 | 56.7 | 97 | 35 | 24 | Φ4.3 | 20 | 95.5 | 20 | G1/4 | 3 | 22 | 75.5 |
| H533-10C | 45 | G1/4 | 7.5 | 40 | 72.5 | 113.5 | 40 | 28 | Φ4.3 | 24 | 100 | 24 | G3/8 | 4 | 27 | 91.5 |
| H534-15C | 63 | G1/2 | 10 | 57 | 104 | 152 | 50 | 36 | Φ5.5 | 28 | 108 | 36 | G1/2 | 4 | 34 | 124 |