

Schilderträger
CPX-ST-1
536593

1. Teilleiste

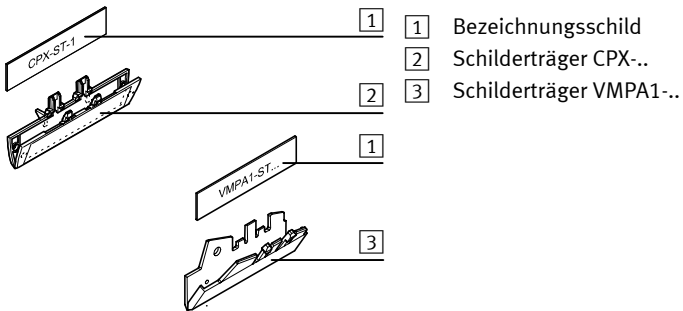

→ **Hinweis**

Diese Montageanleitung gilt auch für
Schilderträger VMPA1-ST-1-4 533362

→ **Hinweis**

Zum Beschriften der Bezeichnungsschilder finden Sie die Word-Vorlage
im Internet unter:

www.festo.com > Länderauswahl > Industrie-Automation > Services & Support
> Download Area > Download Software > Kategorie > Vorlagen für ...

2. Montageablauf

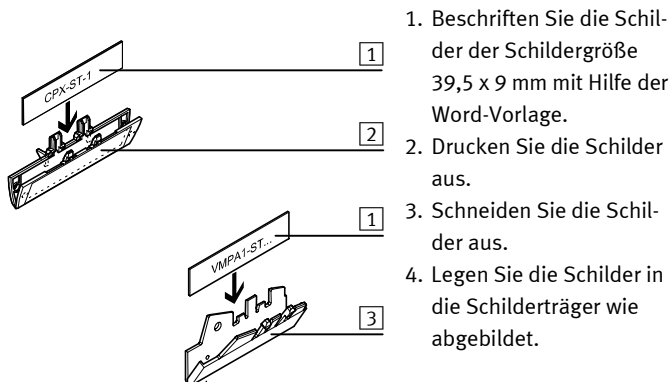

3. Vorlage für Bezeichnungsschild 39,5 x 9 mm

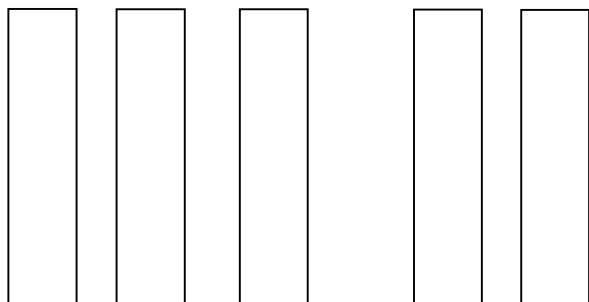
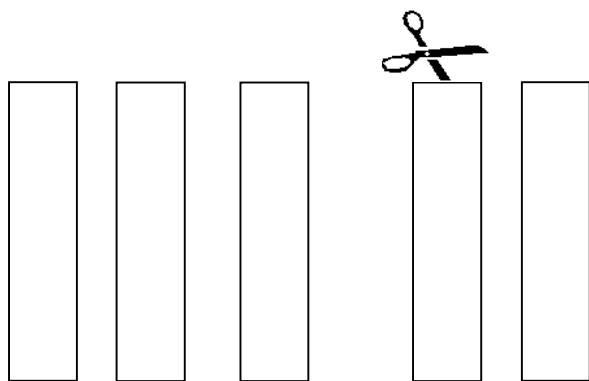
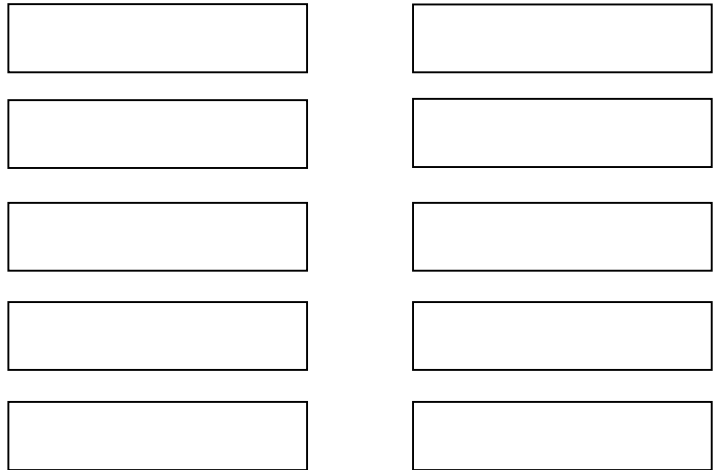

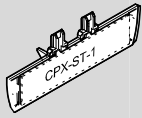

Identification plate holder
CPX-ST-1
536593

1. Parts list

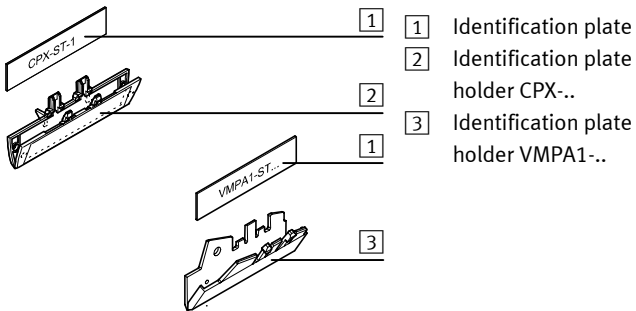

→ **Please note**
These assembly instructions apply also to identification plate holder VMPA1-ST-1-4 533362

→ **Please note**
The Word template for writing on the identification plates can be found in Internet under:
www.festo.com > country selection > Industrial Automation > Services & Support > Download Area > Download Software > Category > Template for ...

2. Assembly sequence

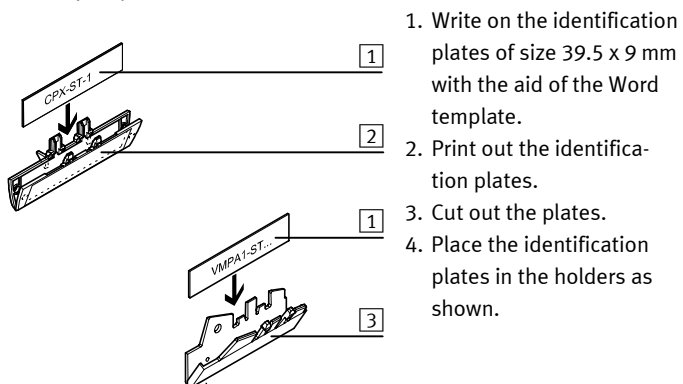

1. Write on the identification plates of size 39.5 x 9 mm with the aid of the Word template.
2. Print out the identification plates.
3. Cut out the plates.
4. Place the identification plates in the holders as shown.

3. Template for identification plates 39.5 x 9 mm

