

SG

Compact Guide Cylinder

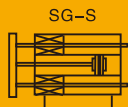

Specifications



Bore(mm)	6	10	12	16	20	25	32	40	50	63
Acting type	Double acting									
Working medium	Clean Air(after 40 μm filtration)									
Working pressure (MPa)	0.1~1.0									
Guaranteed pressure (MPa)	1.5									
Working temperature (°C)	-20~80(No freezing)									
Piston speed (mm/s)	30~500									
Cushion	Rubber cushion									
Stroke tolerance(mm)	+1.0 0									
No-rotating precision ★	SGL	—	± 0.08°	± 0.07°	± 0.06°	± 0.05°				
	SGM	± 0.10°		± 0.09°	± 0.08°	± 0.06°				
Port Size	M3 × 0.5		M5 × 0.8		G1/8 ①			G1/4 ①		

★ Retract position. ① PT、NPT port size is optional.

How to Order?

Series No	Type No	Type	Bore X	Stroke	Magnet No	Thread Type
SG	L: Linear bearing M: Slide bearing		6 10 12 ...	25 50 75 ...	S: With magnet	Blank: G P: PT T: NPT
	Blank: Standard type J: Adjuster type			

Order Example:

SG series, linear bearing, bore 16mm, stroke 30mm, EPR code is: SGL16X30-S
Cylinders with cylinder bore of φ6 and φ10 are available in non-adjustable types and cylinders without linear bearings

Optional Accessories

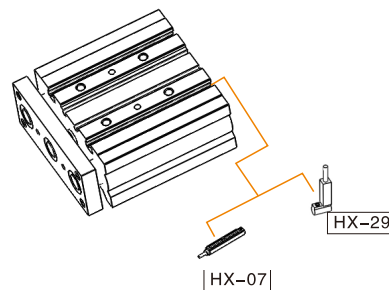

Note: Short stroke please use HX-29 series due to limited space.

Stroke

Bore (mm)	Standard Stroke (mm)	Max. Stroke (mm)
6	5 10 15 20	20
10	5 10 15 20 25 30	30
12	10 20 25 30 40 50 60 70 75 80 90 100 125 150	150
16	10 20 25 30 40 50 60 70 75 80 90 100 125 150 175 200	200
20/25	20 25 30 40 50 60 70 75 80 90 100 125 150 175 200 225 250	250
32-63	25 30 40 50 60 70 75 80 90 100 125 150 175 200 225 250	250

Note: the middle non-standard stroke is made by adding a pad in the cylinder of standard stroke; The φ12~φ32 cylinder diameter corresponds to every 1mm stroke, and the φ40~φ63 cylinder diameter corresponds to every 5mm stroke;

For example, order SGL20*47 non-standard travel cylinder, it is made from SGL20*50 standard travel cylinder with 3mm gasket, its external size, installation size and SGL20*50 the same

How to Mount ?

Fixation of screw on top surface

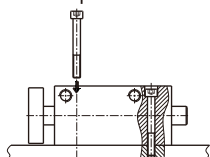

Fixation of screw at bottom surface

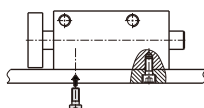

Fixation of screw at back surface

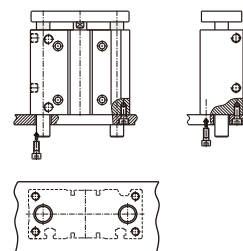

Fixation of T slot at bottom



SG Series Compact Guide Cylinder



Internal Structure

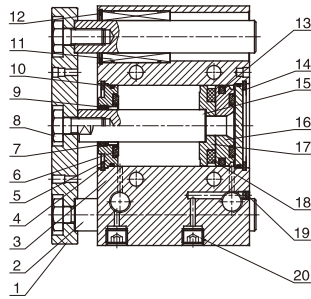

No.	Part Name	Material
1	Fixing plate	Aluminum alloy
2	Leader	Steel
3	Barrel	Aluminum alloy
4	C type retainer ring	Spring steel
5	Head cover	Aluminum alloy
6	Anti-bump cushion	NBR/TPU
7	Piston rod seal	TPU
8	Screw	Stainless steel
9	Self lubricating bearing	Bronze powder
10	O-ring	NBR
11	Linear bearing(SGL) Slide bearing (SGM)	Brass(SGM) Composite material(SGL)
12	C type retainer ring	Spring steel
13	Piston seal	NBR
14	Rear cover	Aluminum alloy
15	Piston rod	S45C hard chrome carbon steel
16	Piston	Aluminum alloy
17	Magnet base	Aluminum alloy
18	Magnet	Plastic
19	Nut	Carbon steel
20	Hex fix screw(G)	Carbon steel
21	Spacer	Aluminum alloy

SGL Series

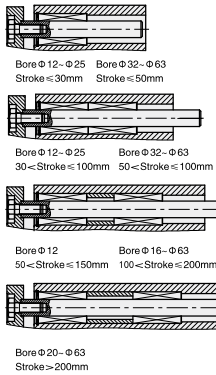

SGM Series

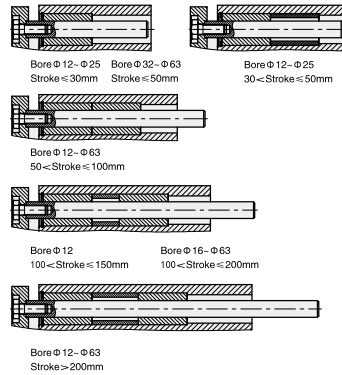

Main Dimension

SGM6S

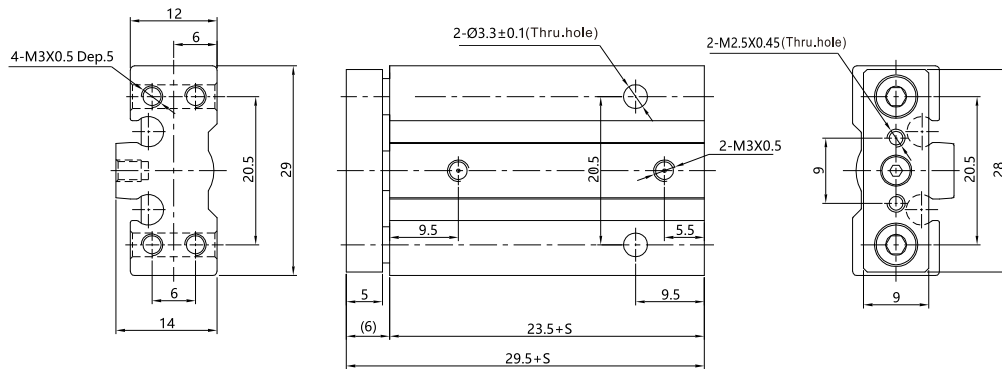

SGM10S

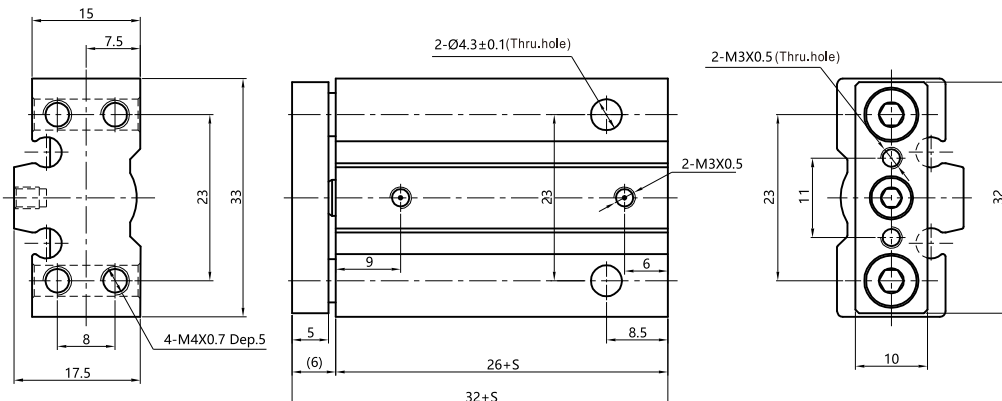

SG Series Compact Guide Cylinder



Main Dimension

SG12~63

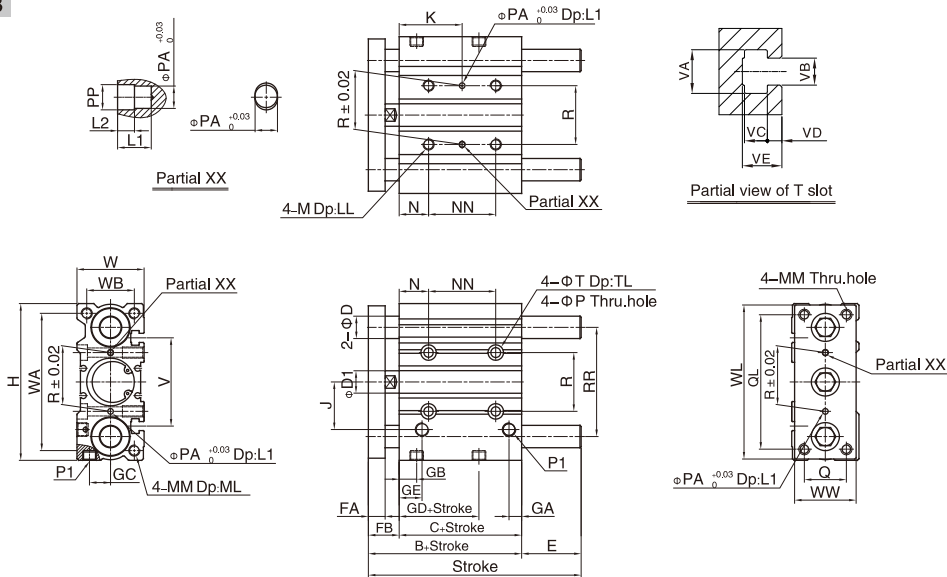

(mm)

Bore/Sign	E(SGL)				E(SGM)				NN				K								
	≤30	31-100	101-200	>200	≤50	51-100	101-200	>200	≤30	31-100	101-200	>200	≤30	31-100	101-200	>200					
12	0	13	43	-	0	13	43	-	20	40	110	-	15	25	60	-					
16	0	19	49	-	0	19	49	-	24	44	110	-	17	27	60	-					
20	0	27	51	69	0	27	51	69	24	44	120	200	29	39	77	117					
25	0	28.5	51	68.5	0	28.5	51	68.5	24	44	120	200	29	39	77	117					
Bore/Sign	≤50	51-100	101-200	>200	≤50	51-100	101-200	>200	≤40	41-100	101-200	>200	≤40	41-100	101-200	>200					
32	5.5	42.5	58.5	80.5	5.5	42.5	58.5	80.5	24	48	124	200	33	45	83	121					
40	0	36	52	74	0	36	52	74	24	48	124	200	34	46	84	122					
50	4	46	62	89	4	46	62	89	24	48	124	200	36	48	86	124					
63	0	41	57	84	0	41	57	84	28	52	128	200	38	50	88	124					
Bore/Sign	B	C	FA	FB	P1	GA	GB	GC	GD	GE	R	RR	N	P	PA	PP	T	TL	M	LL	D1
12	42	29	8	13	M5X0.8	7.5	11	8	13	11	23	41	5	4.2	3	3.5	8	4.5	M5X0.8	10	6
16	46	33	8	13	M5X0.8	8	11	10	15	11	24	46	5	4.2	3	3.5	8	4.5	M5X0.8	10	8
20	53	37	10	16	1/8"	9	10.5	10.5	12.5	10.5	28	54	17	5.2	3	3.5	9.5	5.5	M6X1.0	12	10
25	53.5	37.5	10	16	1/8"	9	11.5	13.5	12.5	11.5	34	64	17	5.2	4	4.5	9.5	5.5	M6X1.0	12	12
32	59.5	37.5	12	22	1/8"	9	12.5	15	7	12.5	42	78	21	6.9	4	4.5	11	7.5	M8X1.25	16	16
40	66	44	12	22	1/8"	10	14	18	13	14	50	86	22	6.9	4	4.5	11	7.5	M8X1.25	16	16
50	72	44	16	28	1/4"	11	12	21.5	9	14	66	110	24	8.7	5	6	14	9	M10X1.5	20	20
63	77	49	16	28	1/4"	13.5	16.5	28	14	16.5	80	124	24	8.7	5	6	14	9	M10X1.5	20	20
Bore/Sign	D(SGL)	D(SGM)	J	W	WA	WB	WL	WW	H	Q	QL	MM	ML	L1	L2	V	VA	VB	VC	VD	VE
12	6	8	18	26	50	18	56	22	58	14	48	M4X0.7	10	6	3	37	7.4	4.4	3.7	2	6.2
16	8	10	19	30	56	22	62	25	64	16	54	M5X0.8	12	6	3	38	7.4	4.4	3.7	2.5	6.7
20	10	12	25	36	72	24	81	30	83	18	70	M5X0.8	13	6	3	44	8.4	5.4	4.5	2.8	7.8
25	12	16	28.5	42	82	30	91	38	93	26	78	M6X1.0	15	6	3	50	8.4	5.4	4.5	3	8.2
32	16	20	34	48	98	34	110	44	112	30	96	M8X1.25	20	6	3	63	10.5	6.5	5.5	3.5	9.5
40	16	20	38	54	106	40	118	44	120	30	104	M8X1.25	20	6	3	72	10.5	6.5	5.5	4	11
50	20	25	47	64	130	46	146	60	148	40	130	M10X1.5	22	8	4	92	13.5	8.5	7.5	4.5	13.5
63	20	25	55	78	142	58	158	70	162	50	130	M10X1.5	22	8	4	110	17.8	11	10	7	18.5

SGJ

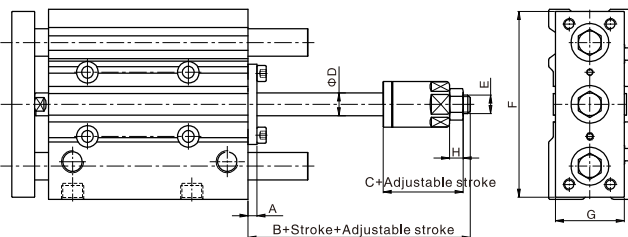

Bore/Sign	A	B	C	D	E	F	G	H
12	3	20	17	6	M5X0.5	56	22	4
16	3	24	21	8	M6X1.0	62	25	5
20	4	29	25	10	M8X1.25	81	30	6
25	5	32	29	12	M10X1.25	91	38	6
32	6	35	29	16	M14X1.5	110	44	8
40	6	35	29	16	M14X1.5	118	44	8
50	8	40	32	20	M18X1.5	146	60	11
63	8	40	32	20	M18X1.5	158	70	11