

Servo motor

EMMB-AS-40-01...

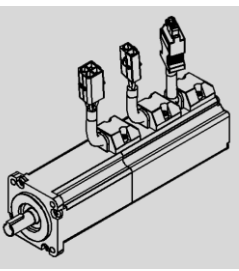

FESTO
 Festo AG & Co. KG
 Rüter Str. 82
 D-73726 Esslingen
 +49 711 347-0
 www.festo.com

Original instructions 8079176
 2017-08a
 [8079177]

EMMB-AS-40-01-... English

Note
 Installation and commissioning may only be performed in accordance with these instructions by technicians with appropriate qualifications.

Additional measures are necessary if used in safety relevant applications, e.g. in Europe the standards listed under the EC machinery directive must be observed. Without additional measures in accordance with statutory minimum requirements, the product is not suitable for use in safety-related sections of control systems.

- Please note that the configuration of the EMMB-AS can be determined based on the rating plate. Depending on the order, this motor contains a holding brake (EMMB-...-SB/-K-SB).

Control sections and connections

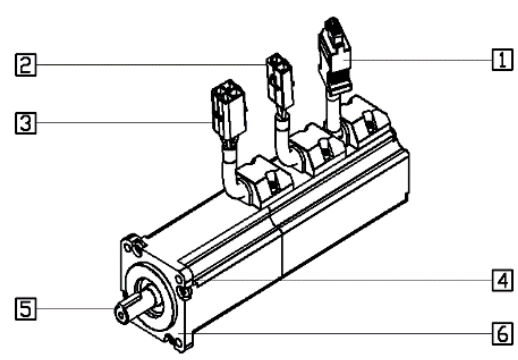

Fig. 1
 1 Plug for connecting cable: – Encoder
 2 Plug for connecting cable: – Holding brake
 3 Plug for connecting cable: – Motor
 4 Holes for mounting
 5 Shaft
 6 Motor flange

Warning
 Dangerous electric voltage
 Do not disconnect the motor connecting cable if voltage is applied.

1 Function and application
 The EMMB-AS is a permanently excited, electrodynamic, brushless servo motor. The EMMB-AS is factory-fitted with a singleturn-encoder. The encoder supplies motor data, speed and position signals to a higher-order controller in the form of digital signals. The motor must always be operated within its permitted characteristic curves (→Characteristic curves).

The EMMB-AS is available with the following options:

EMMB-AS-...	Option
...-S	Shaft w/o key
...-K-S	Shaft with key
...-SB	Shaft w/o key, with holding brake
...-K-SB	Shaft with key, with holding brake

Fig. 2
 Servo motor EMMB-AS has been designed for driving positioning systems. The holding brake of the EMMB-AS-...-SB/-K-SB is **not** suitable for braking the motor.

2 Transport and storage
 Ensure storage conditions as follows:
 – cool, dry, UV and corrosion resistant (→Technical data)

3 Requirements for product use

Note
 Improper handling can result in malfunctions.
 Make sure that the specifications contained in this chapter are adhered to at all times.

- Compare the maximum values specified in these operating instructions with your actual application (e.g. forces, torques, masses, speeds, temperatures). The use of force to move the motor shaft will reduce the functionality of an optional integrated holding brake.
- If necessary, also observe the assembly instructions provided with the mounting components (e.g. gear units or couplings).
- Ensure that all applicable safety regulations are adhered to, e.g. from trade associations or national authorities.
- Use the EMMB-AS in its original state. Unauthorized product modification is not permitted.
- Take into account the prevailing ambient conditions at the location (→Technical data).

4 Installation

Warning
 Open cable ends on the rotating motor can, under certain circumstances, lead to dangerous high voltages.

- First leave the motor uncoupled from the driven mechanical component.
- Make sure that the controller is switched off. Cancelling the Controller Enable signal is not sufficient.
- Connect the EMMB-AS completely to the controller as shown in the following tables. Pre-assembled cables from Festo (→Accessories) offer sufficiently large cable cross-sections as well as screening of the motor/encoder cable with an earth contact on both sides

4.1 Electrical installation



Power plug	Pin	Motor
	1	Phase U
	2	Phase V
	3	Phase W
	4	Protective earth
Brake plug	Pin	Holding Brake
	1	Holding brake BR+ 1)
	2	Holding brake BR- 1)

Fig. 3
 1) Only for motors with holding brake EMMB-AS-...-SB/K-SB

Signal plug	Pin	Encoder
	1	VCC +5V
	2	GND
	3	NC
	4	NC
	5	SD+
	6	SD-

Fig.4

4.2 Mechanical installation

- Clean the shaft of the motor . The coupling will only grip without slipping on a shaft pin which is dry and free of grease.
- Push the slide or the cantilever of the driven mechanical components into a safe position.
- Connect the motor to the driven mechanical component by using the holes  on the motor flange . Pre-assembled motor kits for linear drives can be found in Festo's range of accessories (→Accessories).
- Tighten the mounting screws (Instructions on drive and motor kits). When doing this make sure that no axial force is exerted on the shaft of the motor.

5 Commissioning

→ Note

The motor can unexpectedly be started if the brake is released.

- Secure the relevant mechanical system to prevent it from moving unexpectedly.
- Make sure that the motor windings are not energized before the brake is released.
- Apply current first to the holding brake. This allows the motor to rotate freely. Depending on the type of device, the controller will energise the holding brake automatically.

- Complete the commissioning of the motor in conjunction with the controller in accordance with the controller manual.

6 Operation

Warning

Hot parts of the housing can cause burning.

- Make sure that people and objects cannot come into direct contact with the motor.

7 Maintenance and care

Warning

Dust and dirt deposits can catch fire.

- Clean the motor housing regularly with a damp cloth or brush.

8 Disassembly and repair

Warning

Masses which suddenly slide down may cause injury to people.

- Make sure the motor windings are de-energised before disassembling the motor.
- Make sure that the effective load of the driven mechanical component is in a safe position (e.g. in the case of a vertical installation: in the lower end position).

- You can now remove the EMMB-AS from the mechanical component.
- If repairs are required:
- Return the motor to Festo.
Repairs by Festo will maintain the safety standards.
- Complete the fitting as follows:
 - Push the slide or the cantilever of the driven mechanical components into a safe position.
 - Mount the EMMB-AS (→ Installation).

9 Accessories

→ Note

- Please select the appropriate accessories from our catalogue (www.festo.com/catalogue).

10 Troubleshooting

Malfunction	Possible cause	Remedy
Motor shaft does not turn	Load too high	Reduce motor load
	Controller has not yet been enabled	Check controller signal
	Holding brake active (only with EMMB-AS-...-SB/-K-SB)	Release holding brake
Motor shaft rotates in the wrong direction or vibrates	Cabling fault	Check and correct the cabling
	Incorrect controller parameters	Check and correct controller parameters

Fig.5

11 Technical data

General motor data	...-S/-K-S	...-SB/-K-SB
Output mass moment of inertia [kgcm ²]	0.059	0.063
Product weight [kg]	0.8	1
Radial shaft load [N]	80	
Axial shaft load [N]	40	
Insulation class according to EN 60034-1	F (155 °C)	
Rating class according to EN 60034-1	S1 (continuous operation)	
Conforms to	IEC 60034	
Protection class (motor shaft)	IP50	
Degree of contamination	2	
Ambient temperature [°C]	-20 ... +40	
Relative air humidity [%]	0 ... 90 (non-condensing)	
CE mark (see declaration of conformity) ¹⁾	in accordance with EU EMC Directive in accordance with EU Low Voltage Directive	
Max. cable length [m]	30	
Operating voltage of encoder [V DC]	4.75...5.25	
Encoder current consumption [mA]	130 (max. 170)	
Encoder	Singleturn-encoder 20bit	
Brake voltage (+6 ... -10 %) [V]		24
Brake power consumption [W]		5.9
Brake holding torque ²⁾ [Nm]		0.32

- The device is intended for use in an industrial environment.
In residential areas, measures for radio interference suppression may have to be taken.
- Nominal values according to spec. run-in period. Prolonged periods without operation (e.g. storage) can reduce these values, for example, as a result of settling processes. This effect can be eliminated through repeated operation at low speed

Specific motor data

Nominal voltage [V DC]	300
Frequency range [Hz]	0 ... 400
Nominal current [A]	1.4
Rated torque [Nm]	0.32
Nominal speed [rpm]	3000
Rated output [W]	100
Peak current [A]	4.2
Peak torque [Nm]	0.96
Max. speed [rpm]	6500
Motor constant [Nm/A]	0.265
Winding resistance (20 °C) [Ω]	5.53
Winding inductance (1 kHz) [mH]	6

Fig. 6

→ Note

Certain configurations of the product have been certified by Underwriters Laboratories Inc. (UL) for the USA and Canada. These configurations bear the following mark:



UL Recognized Component Mark for Canada and the United States

Observe the following if the UL requirements are to be complied with in your application:

- Rules for observing the UL certification can be found in the separate special UL documentation. The relevant technical specifications listed there also apply here.
- The technical data in this documentation may show values deviating from this.

12 Characteristic curves

Typical motor characteristics with nominal voltage and idealized controller.

Nominal voltage 300 V

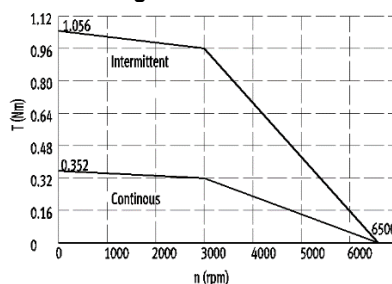

Fig.7