

FESTO

Festo AG & Co. KG

Postfach
73726 Esslingen
Deutschland
+49 711 347-0
www.festo.com

**Stecker
FBS-RJ45-8-GS**

1. Teileliste

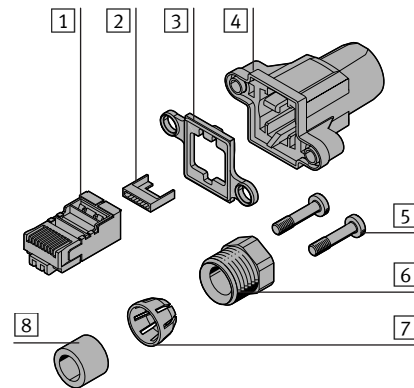

- 1 Stecker RJ45 (1x)
- 2 Kabeleinführhilfe (1x)
- 3 Dichtung (1x)
- 4 Gehäuse (1x)
- 5 Schraube M3x14 (2x)
- 6 Druckschraube (1x)
- 7 Klemmkorb (1x)
- 8 Dichtung (1x)

- Nicht im Lieferumfang:
- (A) Crimpzange für RJ45 (1x)
 - (B) Ethernetkabel (1x)
- (→ Abschnitt 6)

2. Bestimmungsgemäße Verwendung

Stecker FBS-RJ45-8-GS:
Anschluss der RJ45-Schnittstelle am CPX-FEC oder CPX-CEC für die Schutzart IP65/67 in schwing- und schockfester Ausführung.

3. Sicherheitshinweise und Hinweise zur Montage

Info

Mitgeltendes Dokument
→ Bedienungsanleitung der Crimpzange (A)

4. Kontaktbelegung

Pin	Signal	Bezeichnung	Adernfarben ¹⁾ gemäß TIA-568-A ²⁾	Adernfarben ¹⁾ gemäß TIA-568-B ³⁾
1	TD +	Sendedaten +	GNWH	ORWH
2	TD -	Sendedaten -	GN	OR
3	RD +	Empfangsdaten +	ORWH	GNWH
4	n.c.	nicht belegt	BU	BU
5	n.c.	nicht belegt	BUWH	BUWH
6	RD -	Empfangsdaten -	OR	GN
7	n.c.	nicht belegt	BNWH	BNWH
8	n.c.	nicht belegt	BN	BN

5. Montage

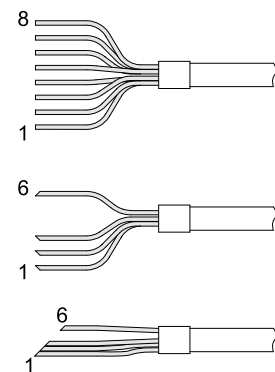
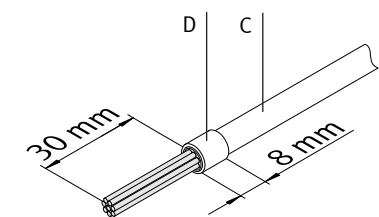
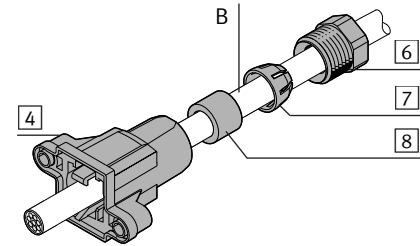

- Folgende Bauteile auf das Kabel (B) schieben:
 - Druckschraube 6
 - Klemmkorb 7
 - Dichtung 8
 - Gehäuse 4

- Kabelmantel (C) auf 30 mm abisolieren.
- Schirmgeflecht (D) auf 8 mm ablängen und auf den Kabelmantel legen.
- Falls vorhanden entfernen:
 - Kabelfüller
 - Kunststoffgeflecht
 - Beilaufitze
 - Schirmfolie

- Adern gemäß Kontaktbelegung (→ Abschnitt 4) nebeneinander ausrichten

- Nicht benötigte Adern nahe der Isolation kürzen.

- Enden der Adern schräg ablängen (ca. 45°).

→ Hinweis

Funktionsstörung durch unsachgemäße Montage.

- Kontaktbelegung entsprechend der für das Netzwerk geltenden Norm wählen (→ Abschnitt 3).

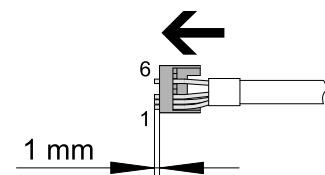
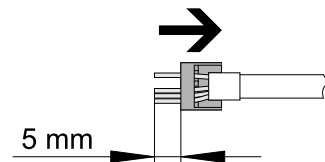
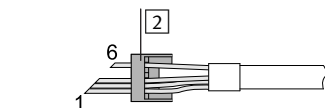

- Adern gemäß Kontaktbelegung (→ Abschnitt 4) in die Kabeleinführhilfe 2 einfädeln.
- Aussparung der Kabeleinführhilfe 2 bündig an den Kabelmantel schieben.

Kontrolle: Adern liegen auf der richtigen Position.

- Adern auf 5 mm ablängen.
- Kabeleinführhilfe 2 in Richtung Kabelende ziehen, bis die Adernenden 1 mm herausstehen.

Info

Bei dickeren, starren Kabeln kann zur Erleichterung der Kabeleinbringung in den RJ45-Einsatz der Kabelmantel mit einem stumpfen Hilfsmittel vorsichtig flachgedrückt werden.

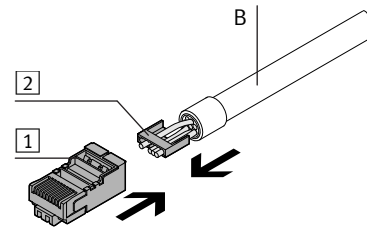

- Stecker 1 vercrimpen (→ Mitgeltendes Dokument).

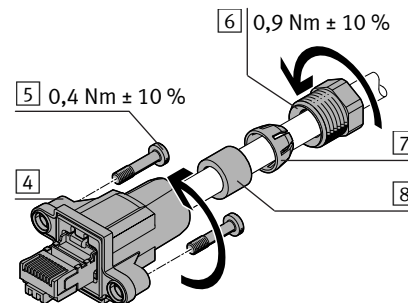
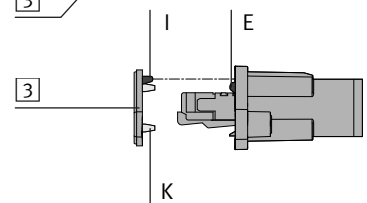
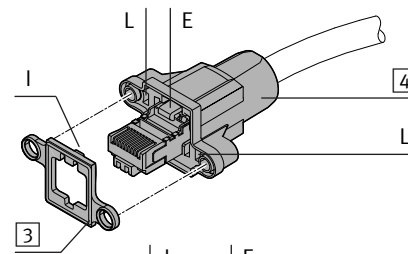
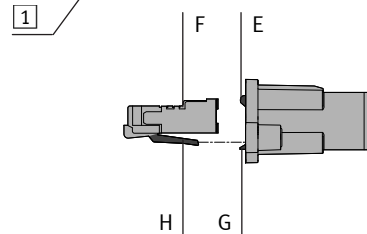
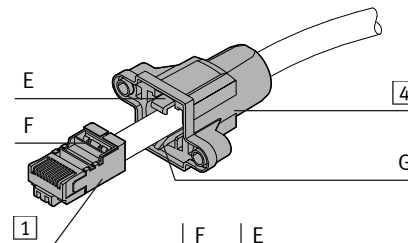

- Kabel (B) mit Kabeleinführhilfe 2 bis zum Anschlag in Stecker 1 schieben.
- Kabel fest eindrücken.
- Alle Adern sitzen auf der richtigen Position.
- Alle Adern liegen an der Vorderseite des Steckers an.

- Stecker 1 bis zum Anschlag in das Gehäuse 4 schieben.
- Der Rasthaken (E) schnappt in die Rastrippe (F) des Steckers 1 ein.
- Kontrolle: Die Rippe (G) drückt den Clip (H) an den Stecker 1.

- Dichtung 3 auf dem Gehäuse 4 platzieren.
- Die Gummilippe (I) als Rastsicherung zwischen Rasthaken (E) und Gehäuse 4 drücken.
- Die Gummizapfen (K) in die Vertiefungen (L) drücken.

- Dichtung 8 in das Gehäuse 4 schieben.
- Klemmkorb 7 in das Gehäuse 4 schieben.
- Druckschraube 6 festdrehen. Anziehdrehmoment einhalten.
- Schrauben 5 festdrehen. Anziehdrehmoment einhalten.

6. Technische Daten

FBS-RJ45-8-GS		
Zulässiger Kabeldurchmesser	[mm]	4 ... 5,4
Spezifikation Ethernetkabel		
Typ		CAT.5
Einzeladerdurchmesser	[mm]	0,89 ... 0,99 AWG 24-26 feindrähtig
Schutzart		IP65, IP67 in montiertem Zustand
Umgebungstemperatur	[°C]	-5 ... +60
Werkstoff		
Dichtungen		NBR
Gehäuse		PA-verstärkt
Schrauben		Stahl

¹⁾ Farbcode nach IEC 60757:1983-01

²⁾ TIA/EIA-568-A:1995-10

³⁾ TIA/EIA-568-B.2:2001-05

plug connector FBS-RJ45-8-GS

FESTO

Festo AG & Co. KG

Postfach
73726 Esslingen
Germany
+49 711 347-0
www.festo.com

1. Parts list

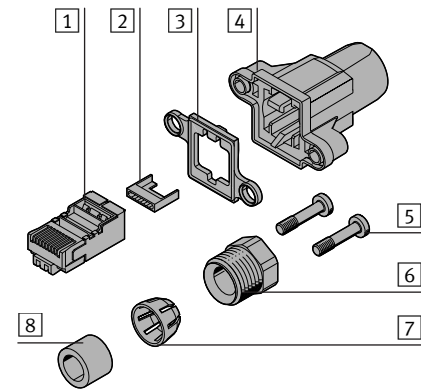

- | | | |
|---|---------------------|------|
| 1 | RJ45 plug connector | (1x) |
| 2 | Cable insert aid | (1x) |
| 3 | Seal | (1x) |
| 4 | Housing | (1x) |
| 5 | M3x14 screw | (2x) |
| 6 | Pressure screw | (1x) |
| 7 | Clamping basket | (1x) |
| 8 | Seal | (1x) |

- Not included in delivery:
- | | | |
|-----|--------------------------|------|
| (A) | Crimping pliers for RJ45 | (1x) |
| (B) | Ethernet cable | (1x) |
- (→ Section 6)

2. Intended use

FBS-RJ45-8-GS connector:
Connection of RJ45 interface to CPX-FEC or CPX-CEC for degree of protection IP65/67 in vibration-resistant and shock-proof version.

3. Safety instructions and notes on mounting

Information

Applicable document

→ Operating instructions for the crimping pliers (A)

4. Pin allocation

Pin	Signal	Designation	Core colours ¹⁾ in accordance with TIA-568-A ²⁾	Core colours ¹⁾ in accordance with TIA-568-B ³⁾
1	TD +	Transmitted data +	GNWH	ORWH
2	TD -	Transmitted data -	GN	OR
3	RD +	Received data +	ORWH	GNWH
4	n.c.	Unused	BU	BU
5	n.c.	Unused	BUWH	BUWH
6	RD -	Received data -	OR	GN
7	n.c.	Unused	BNWH	BNWH
8	n.c.	Unused	BN	BN

5. Mounting

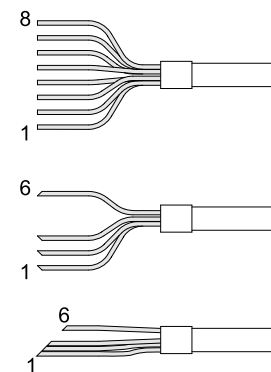
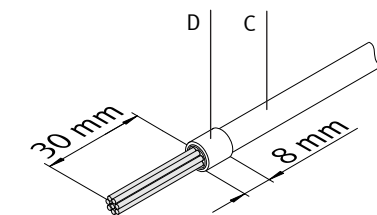
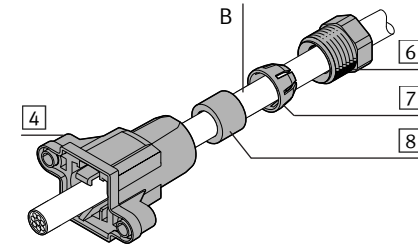

→ Note

Malfunction due to incorrect mounting.

- Select pin allocation in accordance with the standard applicable to the network (→ Section 3).

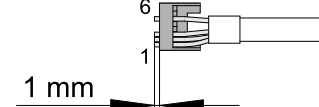
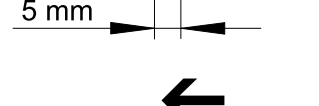
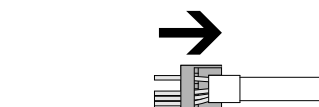
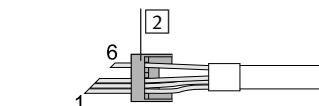

- Slide the following components onto the cable (B):
 - Pressure screw [6]
 - Clamping basket [7]
 - Gasket [8]
 - Housing [4]

- Strip 30 mm of insulation (C) off cable sheath.
- Cut braided screen (D) to length of 8 mm and place on cable sheath.
- If available, remove.
 - Cable filler
 - Plastic braid
 - Secondary braid
 - Sheath film

- Align cores in accordance with pin allocation (→ Section 4) beside one another

- Trim superfluous cores near the insulation.

- Trim ends of cores to length obliquely (approx. 45°).

- Insert cores into cable insert guide [2] in accordance with pin allocation (→ Section 4).

- slide recess on cable insert guide [2] until flush with cable sheath.

Check that cores are in the correct position.

- Cut cores to length of 5 mm.
- Pull cable insert guide [2] towards end of cable until core tips protrude by 1 mm.

Information

On thicker, rigid cables, the cable sheath can be pressed flat using a blunt tool to make it easier to insert in the RJ45 insert.

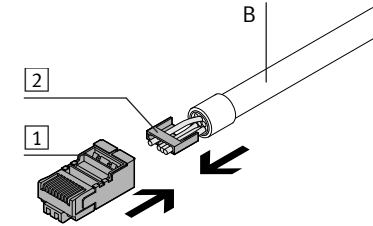

- Crimp connector [1] (→ applicable document).

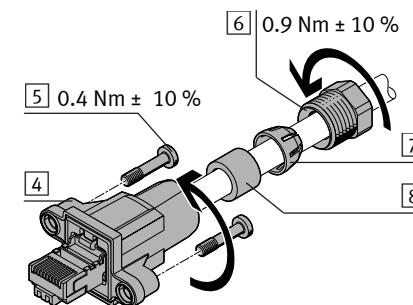
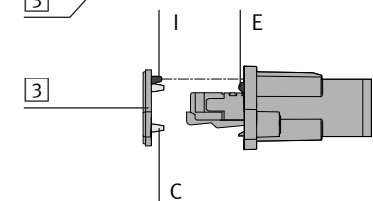
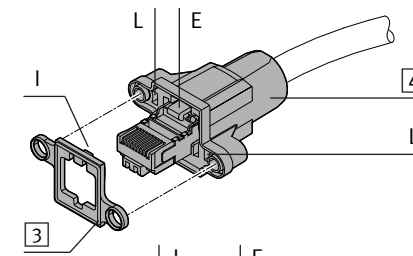
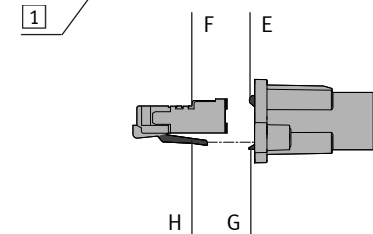
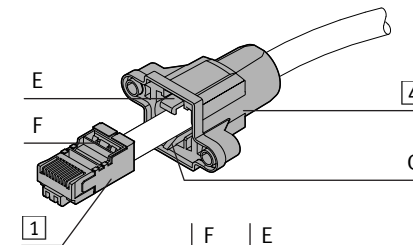

- Slide cable (B) with cable insert guide [2] until firmly home against stop in plug connector [1].
- Press in cable firmly.
 - All cores are located in the correct position.
 - All cores are located on the front of the plug connector.

- Slide plug connector [1] up against stop in housing [4].
 - Detent hook (E) snaps into detect strip (F) on plug connector [1].
- Check: The rib (G) presses the clip (H) against the connector [1].

- Place gasket [3] on housing [4].
 - Press rubber lip (I) in as protector between detent hook (E) and housing [4].
 - Press rubber journal (K) into the recesses (L).

- Slide gasket [8] into housing [4].
- Slide clamping basket [7] into housing [4].
- Tighten down pressure screw [6]. Observe the tightening torque.
- Tighten screws [5]. Observe the tightening torque.

6. Technical data

FBS-RJ45-8-GS		
Permissible cable diameter	[mm]	4 ... 5.4
Ethernet cable specification		
Type		CAT.5
Individual wire diameter	[mm]	0.89 ... 0.99 AWG 24-26 fine wire
Degree of protection		IP65, IP67 in mounted status
Ambient temperature	[°C]	-5 ... +60
Material		
Seals		NBR
Housing		PA-reinforced
Screws in		Steel

¹⁾ Colour code in accordance with IEC 60757:1983-01

²⁾ TIA/EIA-568-A:1995-10

³⁾ TIA/EIA-568-B.2:2001-05