

Driveless guide axis

FDG-...-ZR-RF

FESTO

(en) Operating
instructions

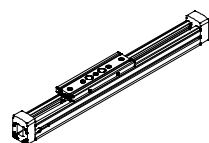
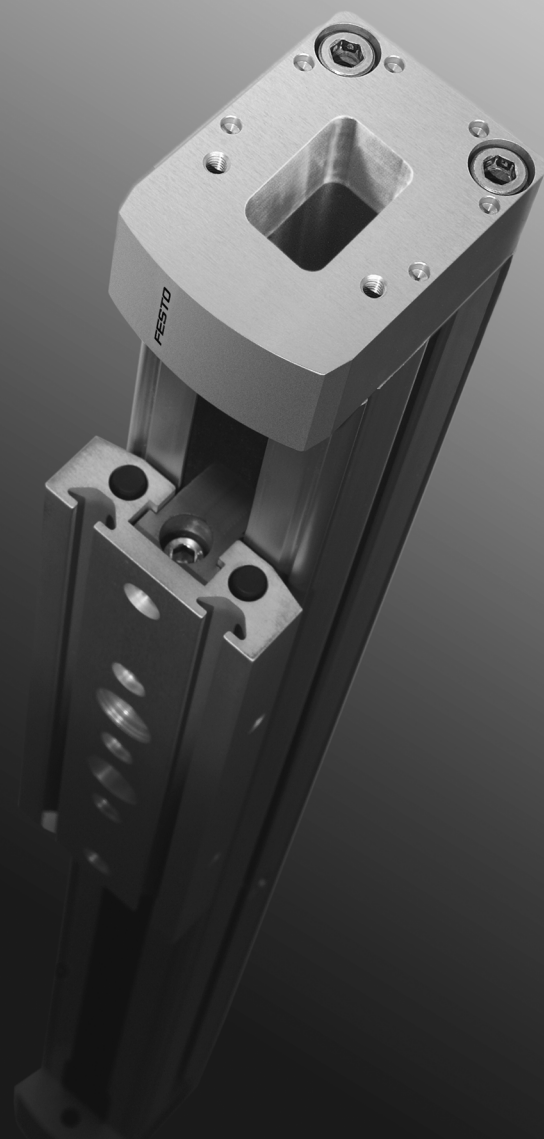

8104202
2018-12a
[8104204]

Translation of the original instructions

Identification of hazards and instructions on how to prevent them:



Danger

Immediate dangers which can lead to death or serious injuries



Warning

Hazards that can cause death or serious injuries



Caution

Hazards that can cause minor injuries

Other symbols:



Note

Material damage or loss of function



Recommendations, tips, references to other documentation



Essential or useful accessories



Information on environmentally sound usage

Text designations:

- Activities that may be carried out in any order
- 1. Activities that should be carried out in the order stated
- General lists
- ➔ Result of an action/References to more detailed information



For all available product documentation → www.festo.com/pk

Passive guide axis type FDG-...-ZR-RF

1 Operating parts and connections

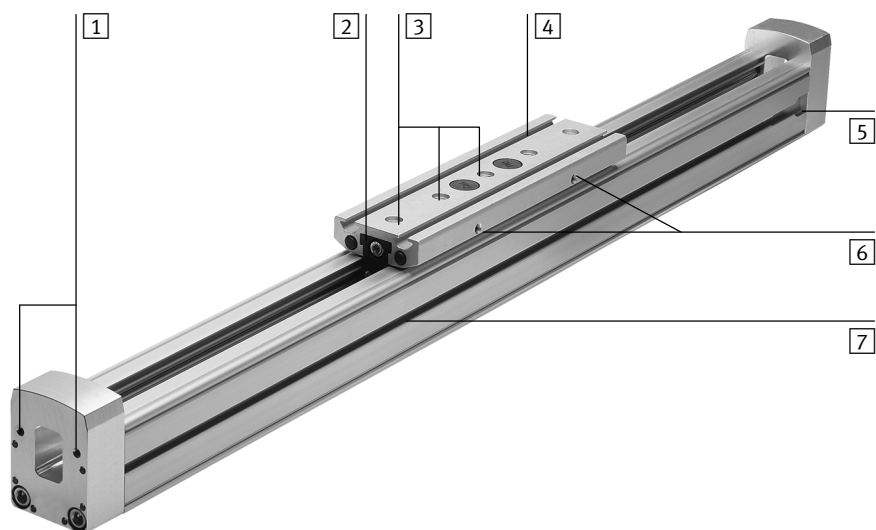

- 1 Internal thread for fastening the axis
- 2 Lubrication nipple
- 3 Centring recesses with or without fastening thread
- 4 Groove for fastening the work load
- 5 Slot for inserting the sliding blocks (only size 25)
- 6 Internal thread for fastening a switching lug
- 7 Groove for fastening the sensor supports

Fig. 1

2 Function

The slides of the guide axis support a load whilst moving.

When the load is shifted along the direction of the axis, the slide follows very smoothly.

An extended slide enables a loading with higher torques.

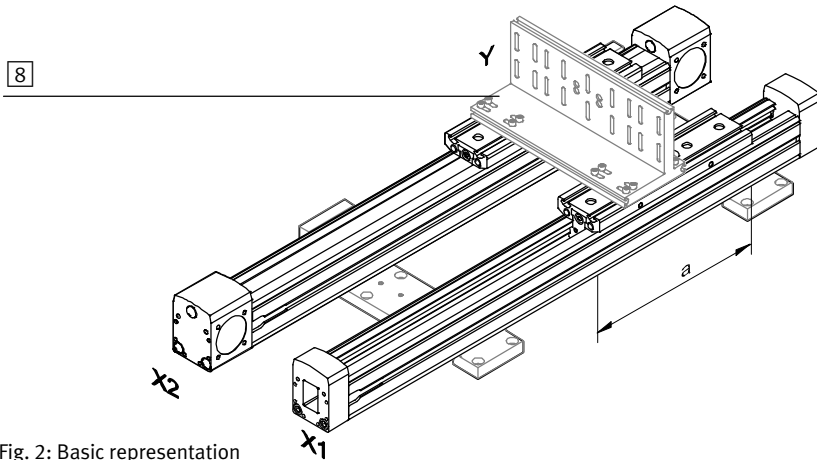

Fig. 2: Basic representation

8 Bridge (transverse connection kit)

3 Application

The FDG-...-ZR-RF has been designed as a basic structure for boom or portal systems consisting of a driving linear axis and a passive guide axis.

4 Conditions of use



Please note

- Make sure that the specifications in this chapter are always observed. The product will then function correctly and reliably.

- Compare the maximum values specified in these operating instructions with your actual application (e.g. forces, masses, temperatures, torques). Only if the loading limits are observed can the product be operated in accordance with the relevant safety guidelines.

- Take into account the ambient conditions at the location.

Corrosive environments will impair the service life of the product.

[°C]

[%]

[mbar]



Fig. 3

- Remove the packing from the product.

The packing is intended for recycling (except for: oiled paper which must be disposed of).



- Observe the specifications applicable to your location, as well as all local and national laws and regulations.
- Use the product in its original state without undertaking any modifications.
- Make sure that safety measures cannot be ignored.

5 Transport and storage

- Consider the weight of the FDG-...-ZR-RF. It weighs up to 100 kg.
- If necessary fasten the slide, which runs very smoothly, with adhesive tape.

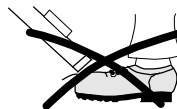

Fig. 4

6 Fitting

Mechanical components

- Make sure that this condition is observed:

Rated stroke FDG-...-ZR-RF \geq Rated stroke drive axis

Example (type plates): FDG-40-800-ZR-RF \geq DGE-40-800-ZR-RF

Only in this way will the multi-axis system function free of collision in the end positions.

- Please note that the rated stroke can be defined differently depending on the axis and the manufacturer:

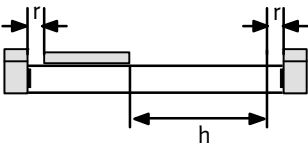
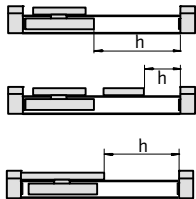
Definition of the rated stroke	
with FDG-...-ZR-RF and DGE-...-ZR-RF:	with other axes/manufacturers:
	
<p>h: Rated stroke r: Stroke reserve</p>	

- Position the FDG-...-ZR-RF without tension or bending (evenness of mounting surface: 0.2 mm/30 cm).
Axis fastening kits, centre supports and foot fastenings will assist you here.



Fig. 5

Please note

Take into account that, in the case of heavy loadings, the axis must not be fastened only at the cover caps.
Excessive tensile loads will cause the cover screws to be pulled out.

In the case of articles with large stroke lengths:

- Use centre support type MUP-... .

Fig. 6 shows the necessary distances between supports.

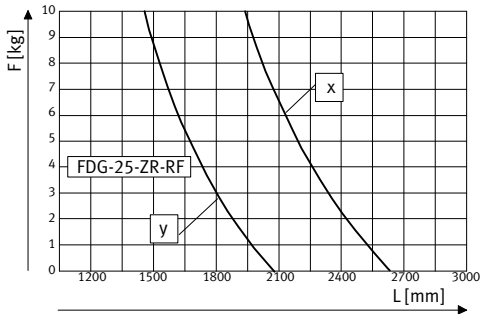

Mounting position x

Mounting position y

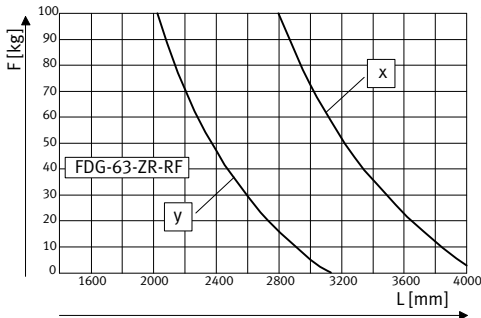
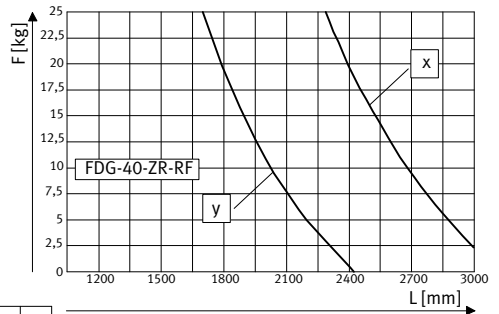
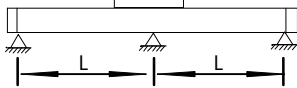
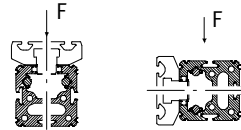

Fig. 6:
Necessary distance between supports L for FDG-...-ZR-RF as a factor of mounting position, rated size and work load F

- Fasten the axis fastening kits or centre supports to the FDG-...-ZR-RF as shown in the following diagram:

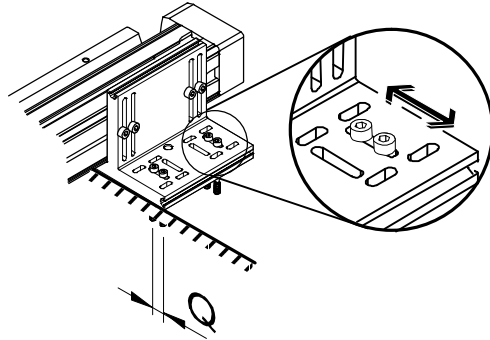

Fig. 7: Q = Play for transverse fastening



If necessary, sliding blocks in the profile grooves can serve as fastening devices.

If the FDG-...-ZR-RF is used in conjunction with a drive axis type DGE-... or DGP(L)-...:

- Use the distances between supports of the drive axis also for the FDG-...-ZR-RF. In this way you will avoid distortion due to uneven bending.
- Tighten the fastening screws for the transverse fastening at first only slightly (see Fig. 7: Q). The FDG-...-ZR-RF can then be further adjusted until it is mounted correctly.



Fitting the fastening elements

- Make sure that the axis fastening kit or the centre supports are situated outside the collision range of the slide, by pushing the slide once over the complete positioning path.

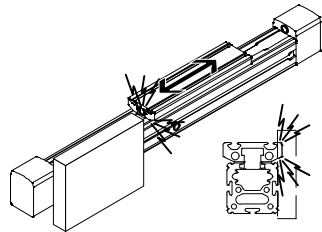

Fig. 8

If the FDG-...-ZR-RF is used in conjunction with a drive axis type DGE-... or DGP(L)-...:

1. Make sure that the slide surfaces of both axes lie at the same level within the complete positioning stroke.
2. Position the FDG-...-ZR-RF exactly parallel to the drive axis.
3. Place the bridge (see Fig. 2) and the work load onto the slides of the FDG-...-ZR-RF and the drive axis as follows:
 - The tilting torque of force F parallel to the cylinder axis and distance d remains low. Force F includes here the inertial force $F = m \cdot a$, the force due to weight and possible external forces.
 - Only loadings within the framework of the permitted values are effective (see “Technical specifications”).

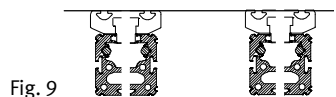

Fig. 9

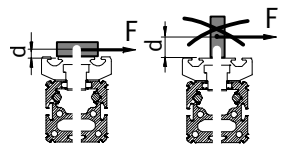

Fig. 10

4. Push the bridge over the complete stroke path from one end position to the other.
The guide axis will then position itself free of distortion to the drive axis.
5. Tighten the fastening screws (see Fig. 7: Q) of the guide axis.

Check whether shock absorbers or stops are also required externally.



Interrogating the slide positions

- Use sensors with inductive switching in conjunction with ferritic switching lugs.
- Complete the fitting of the sensors in accordance with the operating instructions for the sensors and for the drive axis.

You can protect unused sensor grooves against dirt deposits at best with cover rails as described in the chapter “Accessories”.



7 Commissioning and operation



Warning

- Make sure that:
 - nobody can place his/her hand in the path of the moving load (e.g. by providing a protective screen)
 - there are no objects within the positioning path of the axis.

It must not be possible to touch the FDG-...-ZR-RF until the mass has come to a complete stand.

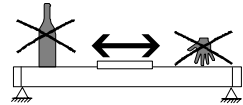

Fig. 11



Please note

The slots in the cover caps enable objects (e.g. nuts or screws), which have fallen unintentionally into the groove, to be extracted.



Warning

Objects ejected from the cover caps can cause injury to human beings or damage to property.

- Make sure that nobody can be hit by these objects if he/she is in their path (e.g. by providing a protective screen).
- Apply current to the drive motor at first at low speed and with low torques. The slide will then move slowly over the complete positioning path.

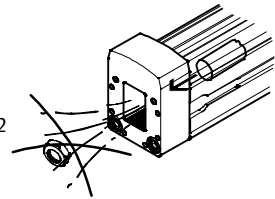

Fig. 12

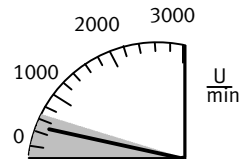

Fig. 13

8 Care and maintenance

- Recommendation:
Return the product to Festo for inspection after every 10,000 kilometres run.
- Do not adjust screws or threaded pins for which there are no direct demands for modification in the operating instructions.

Lubricating the roller guide

- Lubrication interval: as required, in principle at least after 10.000 km.
- Note that lubrication must be carried out more frequently:
 - in dusty and dirty environments,
 - with very short work strokes (running-in at a position).

- Lubricate the FDG-...-ZR-RF at the lubrication nipples on both sides of the slide.
Oil: e.g. Constant OY 390 from Klüber, München
Grease gun: see Accessories.
Fitted into restricted spaces:

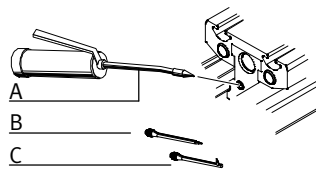

Fig. 14

- Use blast pipe B (axial opening) or C (radial opening) instead of the standard blast pipe A.
- Move through the rated stroke once completely in order to distribute the oil evenly in the interior of the FDG-...-ZR-RF.

At each maintenance procedure:

- Check that the slide is set free of play and distortion.
If you find something unusual, see the chapter “Eliminating faults”.

9 Repairs

Faults during operation

- Make sure that the FDG-...-ZR-RF is overhauled only by our repair service (e.g. if there is play between the slide and the guide).
In this way you will prevent damage to the axis at a later stage. The repair procedures require settings with very accurate adjustments.

10 Accessories

Type	Designation
MUP-...	Centre supports
HP-...	Foot fastening
HMAV-...	Adapter kit HMP-...
HMSV-...	Adapter kit SLT-...
HMVA-...	Actuator adapter kit
HMVD-...	Twin cantilever axis kit
HMVG-...	Axis connecting kit (for distance between axes ≤ 200 mm)
HMVJ-...	Adjusting kit
HMVK-...	Cross connecting kit
HMVS-...	Twin axis support kit
HMVT-...	Twin axis connecting kit
HMVV-...	Reinforcing kit
SIEN-...	Sensor with normally-open / normally-closed function
HWS-...	Sensor support
SF-...	Switching lug
SIM-...	Extension cable
ZBH-...	Centring sleeves
NST/NSTL-...	Sliding blocks
ABP-...	Groove cover rail
647 958	Grease gun with pinpoint nozzle
647 959	Blast pipe, axial opening
647 960	Blast pipe, radial opening

Fig. 15

11 Eliminating faults

Fault	Cause	Remedy
Loud running noises and sluggish slide	Insufficient lubrication of the slide bearing	Lubricate, if necessary return to Festo
Red-brown colouring on the guide rods	Rust due to insufficient lubrication	
Noticeable play on the slide	Wear, damage	Return product to Festo
Sluggishness of a twin arrangement near the end position	Insufficient parallelism between drive and FDG-...-ZR-RF	Readjust axes
“Engaging” at a position	long downtime	Disappears after a new start-up phase
Vibration	Axis overloaded	Observe maximum loading values
	Dynamics too high	Check modifications to project planning
	Incorrect arrangement of the centre of gravity of the work load	Shift centre of gravity
	External interference on base stand or in multi-axis system	Eliminate interference
Missing or undefined switching functions	Proximity switch or cable defective	Replace defective part
	Sensor support or switching lug incorrectly fitted	Correct fitting
	Switching gap set incorrectly	Readjust
	Switch or connection incorrect	Replace incorrect part

12 Technical specifications

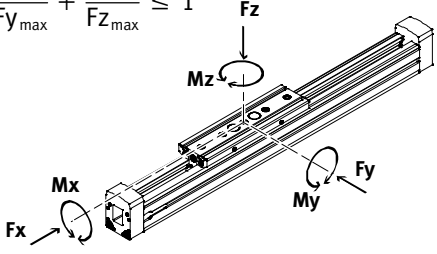
	FDG-25-ZR-RF	FDG-40-ZR-RF	FDG-63-ZR-RF
Design	Passive guide axis with roller guide		
Temperature	0 ... + 60 °C (storage/operation)		
Mounting position	As desired		
Slide speed	max. 10 m/s		
Permitted work load			
horizontal	10 kg	25 kg	50 kg
vertical	5 kg	12.5 kg	25 kg
Permitted transverse load F_y, F_z	150 N	300 N	600 N
Permitted torque loading: (values in brackets for variant GV)			
M_x [Nm]	7	18	65
M_y [Nm]	15 (30)	60 (120)	170 (340)
M_z [Nm]	15 (30)	90 (180)	300 (600)
$\frac{ M_x }{M_{x_{max}}} + \frac{ M_y }{M_{y_{max}}} + \frac{ M_z }{M_{z_{max}}} + \frac{ F_y }{F_{y_{max}}} + \frac{ F_z }{F_{z_{max}}} \leq 1$ 			
Materials			
Slide, cylinder barrel, cover:	aluminium		
Rollers, screws, sliding blocks:	steel		
Buffer, wiper strip:	rubber, felt		
Cover of slide in slot:	IXEF		
Guide rods:	steel		

FDG-...-ZR-RF

Copyright:
Festo AG & Co. KG
Ruiter Straße 82 Postfach
73734 Esslingen
Germany

Phone:
+49 711 347-0

Fax:
+49 711 347-2144

E-mail:
service_international@festo.com

Internet:
www.festo.com

Reproduction, distribution or sale of this document or communication of its contents to others without express authorization is prohibited. Offenders will be liable for damages. All rights reserved in the event that a patent, utility model or design patent is registered.