

Adapterbausatz HAPG – HGPL, HGPLE

FESTO

Festo AG & Co. KG

Postfach
D-73726 Esslingen
++49/(0)711/347-0
www.festo.com

Info

- Beachten Sie, dass bei einigen Kombinationen Befestigungselemente übrig bleiben.

Bei Linearmodul HME (→Bild 1+2):

- Beachten Sie, dass bei der Montage die Antriebsstange **4** gegebenenfalls demontiert werden muss. Lesen Sie dazu die Bedienungsanleitung des Linearmoduls.

Um die Greifrichtung der Greifer zu ändern:

Zu Bild 1, 2 +5:

- Beachten Sie, dass hier eine Änderung der Greifrichtung nicht möglich ist.

Zu Bild 3 + 4:

- Montieren Sie die Adapterplatte **2** um 90° versetzt auf den Antrieb **1**.

1. Montage

- Wählen Sie die Befestigungselemente (Schrauben, usw.) für Ihre Kombination (→ Tabelle).
- Beachten Sie die Bildzuordnung für Ihre Kombination (→ Tabelle).

Bild 1

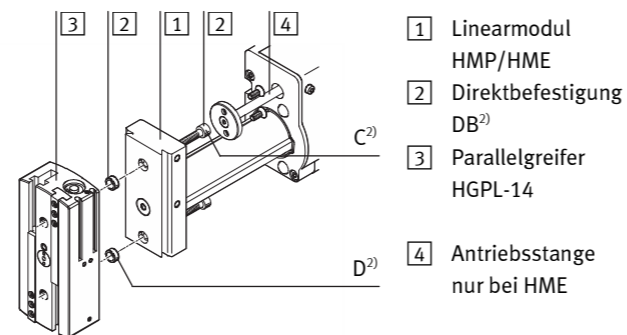

- 1 Linearmodul HMP/HME
- 2 Direktbefestigung DB²⁾
- 3 Parallelgreifer HGPL-14
- 4 Antriebsstange nur bei HME

Bild 2

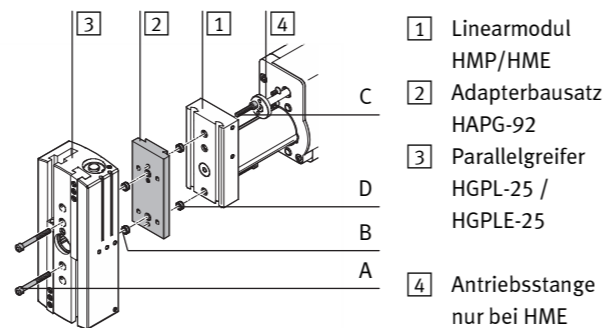

- 1 Linearmodul HMP/HME
- 2 Adapterbausatz HAPG-92
- 3 Parallelgreifer HGPL-25 / HGPLE-25
- 4 Antriebsstange nur bei HME

Bild 3

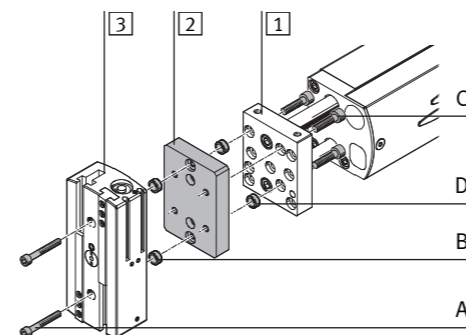

- 1 Linearmodul HMPL
- 2 Adapterbausatz HAPG-93
- 3 Parallelgreifer HGPL-14

Bild 4

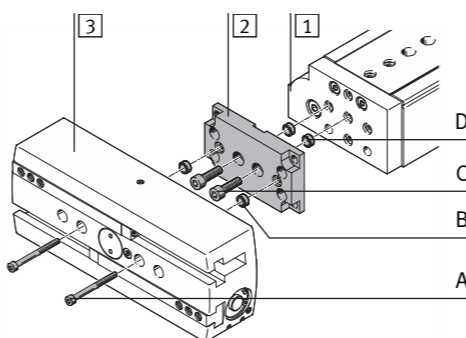

- 1 Mini-Schlitten DGSL/EGSL
- 2 Adapterbausatz HAPG
- 3 Parallelgreifer HGPL/HGPLE

Bild 5

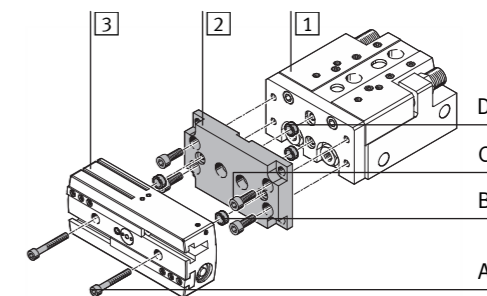

- 1 Mini-Schlitten SLT
- 2 Adapterbausatz HAPG
- 3 Parallelgreifer HGPL/HGPLE

1 Antrieb	HMP-HME-	HMP-	HMP-	HMP-HME-	HMPL-	DGSL-			EGSL-		SLT-				
	16	20	20 ⁴⁾	25	16/20 ⁴⁾	16	20/25	25	45/55	75	16 ⁴⁾	20 ⁴⁾	25	20 ⁴⁾	25 ⁴⁾
2 Bausatz	DB ²⁾		HAPG-		HAPG-	HAPG-			HAPG-		HAPG-				
			92		93	89	90	89		90	89	90	90		
3 Greifer	HGPL-		HGPL-HGPLE-		HGPL-	HGPL-	HGPL-	HGPL-HGPLE-	HGPL-	HGPL-	HGPL-HGPLE-	HGPL-	HGPL-	HGPL-HGPLE-	
	14		25		14	14	14	25	14	14	25	14	14	25	
Bild	1		2		3	4			4		5				
	M _A ¹⁾ [Nm]														
A Zylinderschraube nach DIN 912															
M4x30	3				2x		2x	2x	2x		2x	2x	2x		
M4x45							2x				2x			2x	2x
M5x45	6		2x		2x										
B Zentrierhülse															
ZBH-9			2x		2x	2x	2x	2x	2x	2x	2x	2x	2x	2x	2x
C Zylinderschraube nach DIN 912															
M5x14											4x		4x		
M5x16											4x				
M5x20	2x ³⁾				4x		2x	2x							
M5x25	2x ³⁾		2x	2x	2x ³⁾										
M5x30	6				2x ³⁾										
M6x16	10												4x		4x
M6x20							2x	2x	2x		2x				
D Zentrierhülse															
ZBH-7							2x		2x		2x				
ZBH-9	2x ²⁾		2x ²⁾	2x	2x	2x	2x		2x	2x		2x	2x		
ZBH-12													2x		2x

¹⁾ Toleranzen für nicht tolerierte Anziehdrehmomente M_A
M_A > 1 Nm: ± 20%

²⁾ DB = Direktbefestigung / Zentrierhülsen liegen dem Greifer bei.

³⁾ Lange Schrauben: HMP
Kurze Schrauben: HME

⁴⁾ Diese Kombination ist bei Greifer mit Hub > 60 mm nicht zugelassen.

Adapter kit HAPG – HGPL, HGPLE

FESTO

Festo AG & Co. KG

Postfach
D-73726 Esslingen
++49/(0)711/347-0
www.festo.com

Information

- Please note that mounting components may be left over with some combinations.

With linear module HME (→ Fig. 1+2):

- Note that during assembly the drive rod **4** may need to be dismantled. Refer to the operating instructions for the linear module in this case.

To change the gripping direction of the grippers:

In figure 1, 2 +5:

- Please note that changing the gripping direction is not possible here.

In figure 3 + 4:

- Mount the adapter plate **2** on the drive **1** at 90°.

2. Mounting

- Select the mounting components (screws etc.) for your combination (→ Table).
- Observe the reference figures/illustrations for your combination (→ Table).

Fig. 1

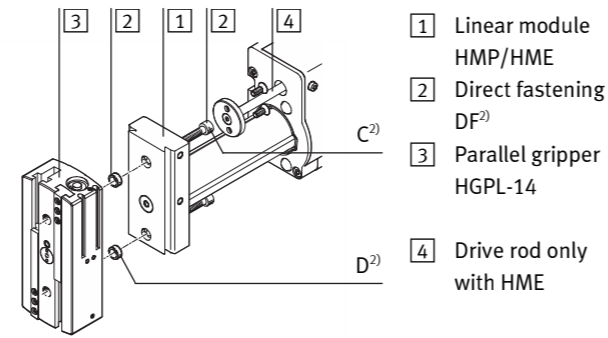

Fig. 3

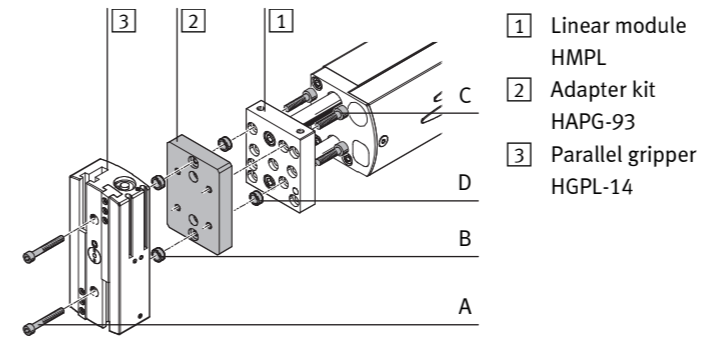

Fig. 5

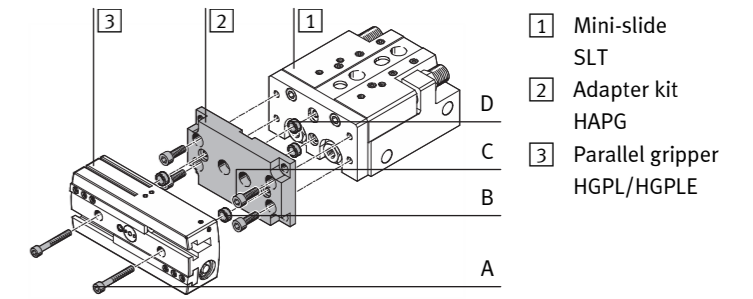

Fig. 2

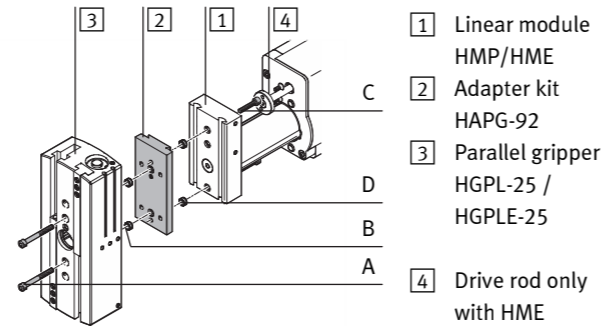
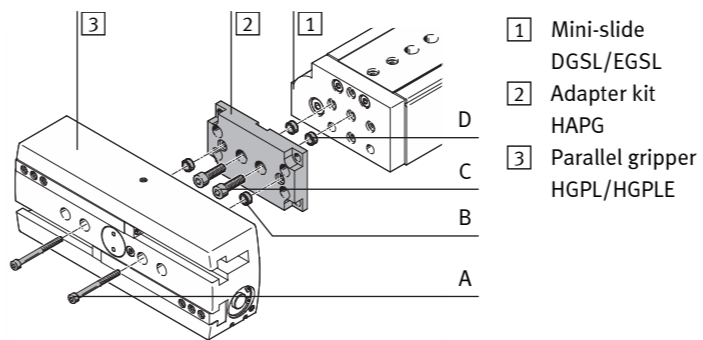

Fig. 4



1 Drive	HMP-HME-	HMP-	HMP-	HMP-HME-	HMPL-	DGSL-			EGSL-		SLT-					
	16	20	20 ⁴⁾	25	16/20 ⁴⁾	16	20/25	25	45/55	75	16 ⁴⁾	20 ⁴⁾	25	20 ⁴⁾	25 ⁴⁾	
2 Kit	DB ²⁾		HAPG-		HAPG-	HAPG-			HAPG-		HAPG-					
			92		93	89	90		89	90	89	90		90		
3 Gripper	HGPL-		HGPL-HGPLE-		HGPL-	HGPL-	HGPL-	HGPL-HGPLE-	HGPL-	HGPL-	HGPL-HGPLE-	HGPL-	HGPL-		HGPL-HGPLE-	
	14		25		14	14	14	25	14	14	25	14	14	25		
Fig.	1		2		3	4			4		5					
	M _A ¹⁾ [Nm]															
A Socket head screw to DIN 912																
M4x30	3				2x		2x	2x	2x		2x	2x	2x			
M4x45							2x				2x				2x	2x
M5x45	6		2x		2x											
B Centring sleeve																
ZBH-9			2x		2x	2x	2x	2x	2x	2x	2x	2x	2x	2x	2x	2x
C Socket head screw to DIN 912																
M5x14													4x	4x		
M5x16											4x					
M5x20			2x ³⁾			4x		2x	2x							
M5x25			2x ³⁾	2x	2x	2x ³⁾										
M5x30	6				2x ³⁾											
M6x16	10												4x		4x	
M6x20							2x	2x	2x		2x					
D Centring sleeve																
ZBH-7							2x		2x		2x					
ZBH-9			2x ²⁾	2x ²⁾	2x	2x	2x	2x		2x	2x	2x		2x		
ZBH-12													2x		2x	

¹⁾ Tolerance for non-toleranced tightening torques M_A
M_A > 1 Nm: ± 20%

²⁾ DF = Direct fastening / centring sleeves are supplied with the gripper.

³⁾ Long screws: HMP
Short screws: HME

⁴⁾ This combination is not permitted for grippers with stroke length > 60 mm.