

Abzweigmodul MS4-/MS6-A-IPM-80

FESTO

Festo AG & Co. KG

Postfach
73726 Esslingen
++49/(0)711/347-0
www.festo.com

1. Teileliste

- 1 Nutenstein (2x)
NST-8-M6
- 2 Anschlussplatte
MS4-6-IPM-40-80
- 3 Senkschraube (2x)
M6x16
- 4 Modulverbinder
MS4-/MS6-IPM
- 5 Hohlschraube
MS4-6-IPM
- 6 Modulverbinder
MS4-/MS6-MV
- 7 O-Ring
MS4: 19x2 / MS6: 29x3
- 8 O-Ring
13x2

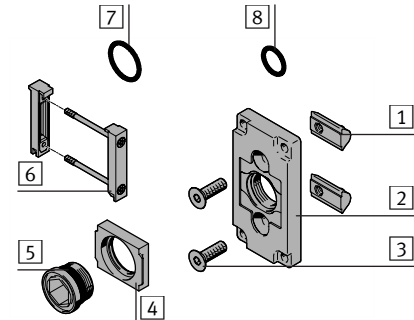

Nicht im Lieferumfang:

- 10 Profil
40x80/80x80
- 11 Bohrvorrichtung
- 12 Flachdichtung
MS4-/MS6-NNR
- 13 Wartungsgerät
MS4-.../ MS6-...

Bestimmungsgemäß dient das Abzweigmodul MS4-/MS6-A-IPM-80 zur Montage eines Wartungsgeräts 13 an die Längsseite eines Profils 10.

→ Hinweis

Der Modulverbinder MS4-/MS6-IPM 4 ist auch um 90° versetzbar für die waagrechte Montage des Wartungsgeräts 13. Beachten Sie jedoch hierbei die gerätespezifischen Vorgaben zur Einbaulage.

2. Vorbereitung zur Montage ↓

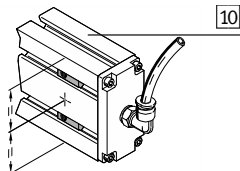

Die notwendige Bohrung muss mittig angeordnet werden.

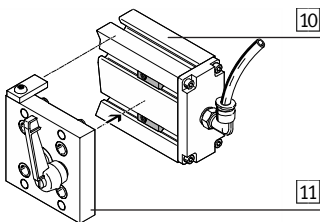

Mit Hilfe der passenden Bohrvorrichtung 11 von Festo wird die genaue Position der Bohrung gewährleistet.

- Stellen Sie sicher, dass keine Späne im Inneren des Profils 10 verbleiben.

Beim Bohren das Profilinnere ggf. unter Druck setzen.

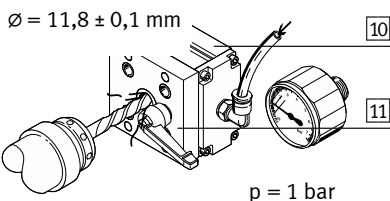

$\varnothing = 11,8 \pm 0,1 \text{ mm}$

$p = 1 \text{ bar}$

⚠ Vorsicht

Herumfliegende Späne! Augenverletzungen könnten die Folge sein.

- Schützen Sie Ihre Augen mit einer Schutzbrille.

3. Montage ↓

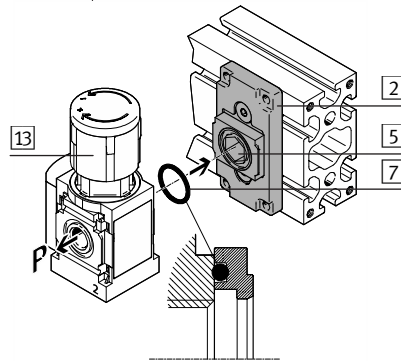
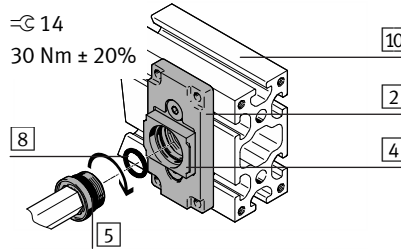
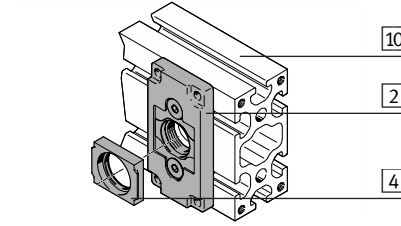
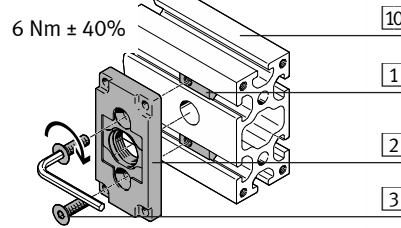

Bei Verwendung des Wartungsgeräts 13 als Abzweigmodul.

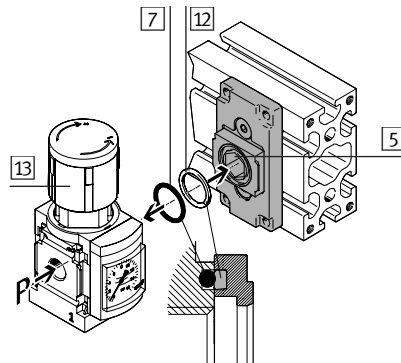

Bei Verwendung des Wartungsgeräts 13 als Einspeisemodul.

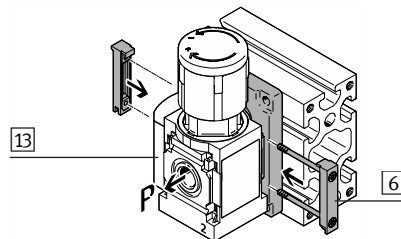

Hierbei wird Flachdichtung 12 benötigt.

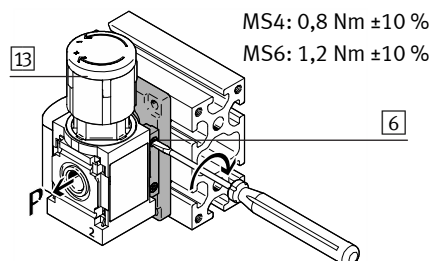

MS4: 0,8 Nm \pm 10 %

MS6: 1,2 Nm \pm 10 %

Branching module MS4-/MS6-A-IPM-80

FESTO

Festo AG & Co. KG

Postfach
73726 Esslingen
++49/(0)711/347-0
www.festo.com

1. Parts list

- 1 Slot nut (2x)
NST-8-M6
- 2 Connection plate
MS4-6-IPM-40-80
- 3 Countersunk screw (2x)
M6x16
- 4 Module connector
MS4-/MS6-IPM
- 5 Hollow bolt
MS4-6-IPM
- 6 Module connector
MS4-/MS6-MV
- 7 O-ring
MS4: 19x2 / MS6: 29x3
- 8 O-ring
13x2

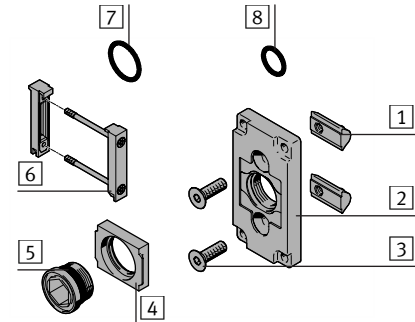

Not included in scope of delivery:

- 10 Profile
40x80/80x80
- 11 Drilling machine
- 12 Flat seal
MS4-/MS6-NNR
- 13 Service unit
MS4-.../ MS6-...

The branching module MS4-/MS6-A-IPM-80 is intended for the assembly of a service unit 13 to the longitudinal side of a profile 10.

→ Note

The module connector MS4-/MS6-IPM 4 can also be repositioned by 90° for the horizontal assembly of a service unit 13. Please observe the device-specific specifications regarding the mounting position.

2. Preparing for assembly ↓

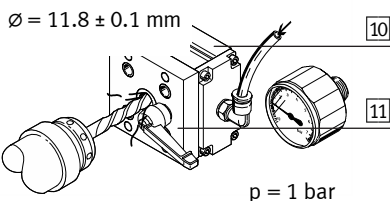
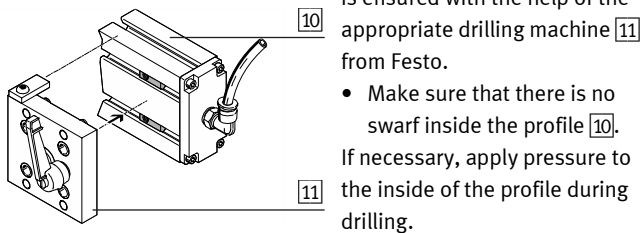
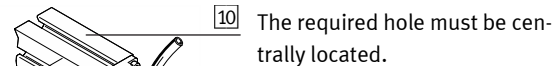

Caution

Flying swarf!
Danger of eye injury.

- Protect your eyes with safety goggles.

4. Assembly ↓

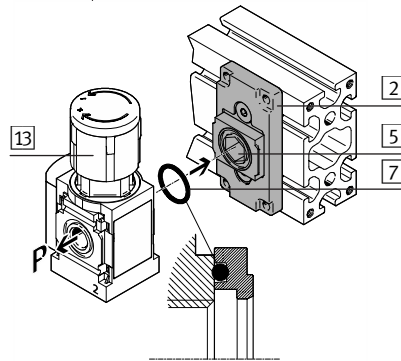
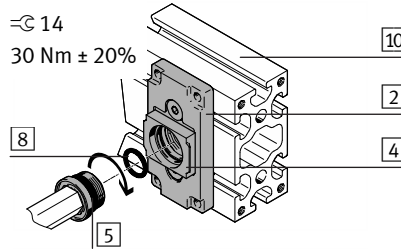
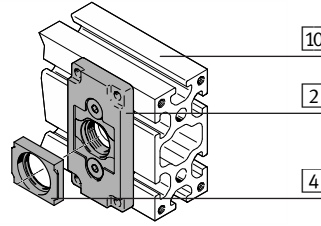
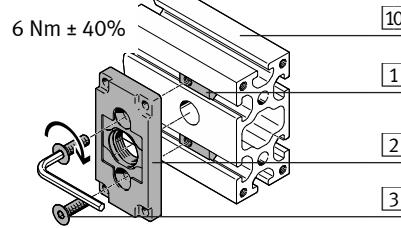

If using the service unit 13 as a branching module.

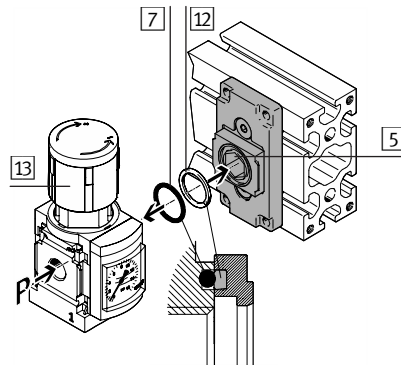

If using the service unit 13 as a power supply module.

The flat seal 12 is required in this case.

