

Planar surface gantries EXCH

FESTO

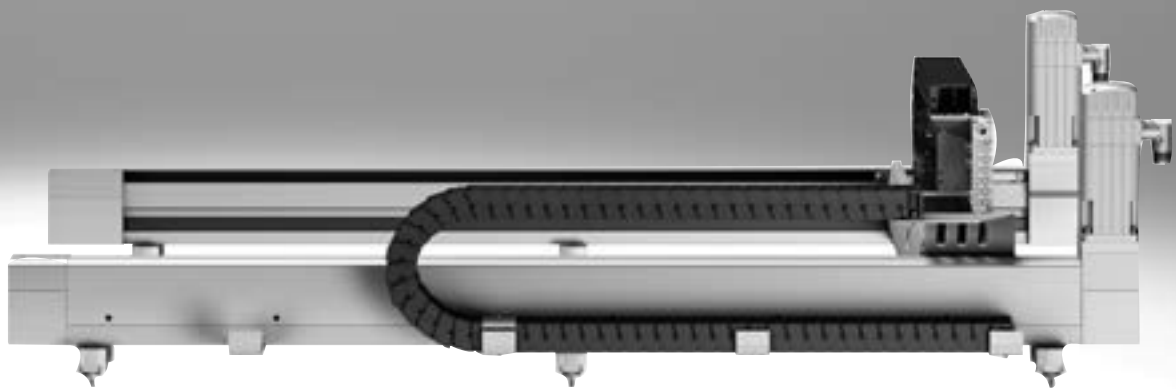

Characteristics

At a glance

General information

- Optimal dynamic response when compared with other Cartesian gantry systems
- The drive concept ensures low moving dead weight
- Flat system design
- Perfectly matched drive and controller package
- High acceleration in both axis directions

Application examples

- Fast repositioning of parts and modules in a large, rectangular working space, e.g.:
 - Sorting
 - Loading, unloading
 - Gluing, cutting

Operating principle

A slide is moved in a two-dimensional space (X-axis/Y-axis) via a toothed belt. The system is powered by two fixed motors. The motors are coupled to the toothed belt. The belt is guided via pulleys so that the slide can move to any position in a working space when the motors are actuated.

When using attachment components, additional processes can be carried out by independent Z-axes.

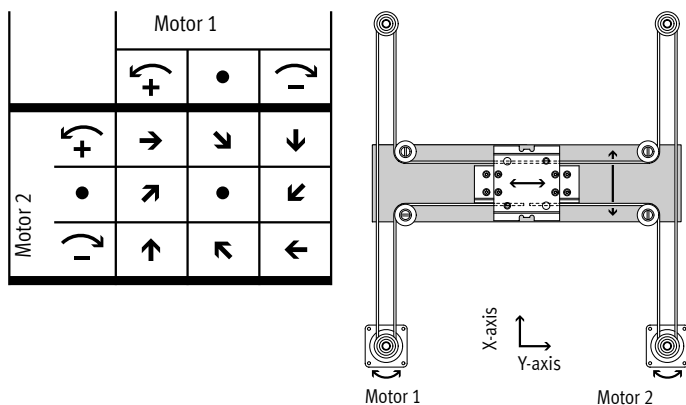

Type		EXCH-40	EXCH-60
Guide		Recirculating ball bearing guide	
Stroke of the			
X-axis	[mm]	200 ... 2000	500 ... 2500
Y-axis	[mm]	200 ... 1000	500 ... 1500
Z-axis	[mm]	50, 100, 150, 200	
Rated load at max. dynamic response ¹⁾	[kg]	4	6
Max. speed			
Horizontal	[m/s]	5	5
Vertical	[m/s]	4	3
Max. acceleration			
Horizontal	[m/s ²]	50	
Vertical	[m/s ²]	30	
Repetition accuracy ²⁾	[mm]	±0.1	
Mounting position ³⁾		Horizontal or vertical	

1) Rated load = tool load (attachment component (Z-axis) + gripper, for example) + payload
 2) The repetition accuracy relates to the centre point of the slide
 3) Vertical mounting position only permitted with motors with brake and braking resistors

Characteristics

Motor mounting variants

EXCH-...-B – Motor underneath

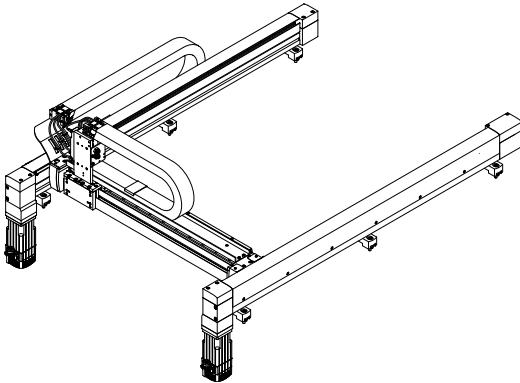

EXCH-...-T – Motor on top

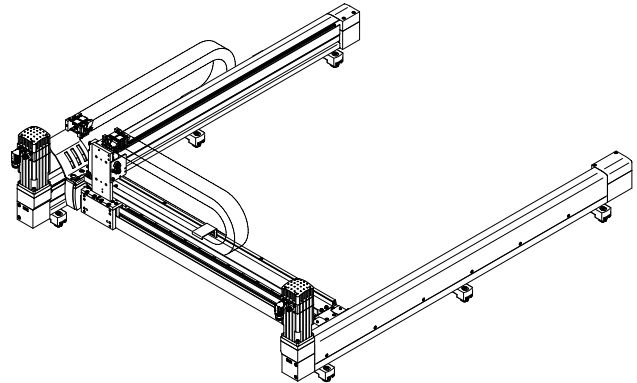

Mounting positions

Horizontal

- Installation always has energy chain at the top

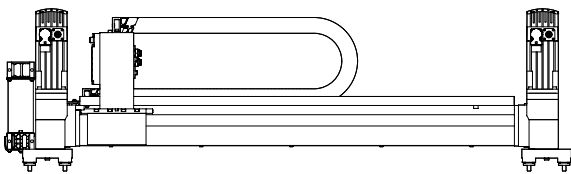

Vertical

- Only the X-axes may be installed vertically
- Motors must be on top so that the energy chain can hang freely
- In combination with a control cabinet, the integrated safety relay unit with power failure detection (order code S2) must be ordered
- Only in combination with the more powerful motors.
 - EXCH-40: order code AB2
 - EXCH-60: order code AB3
- Only use motors with brake
- Braking resistors are essential

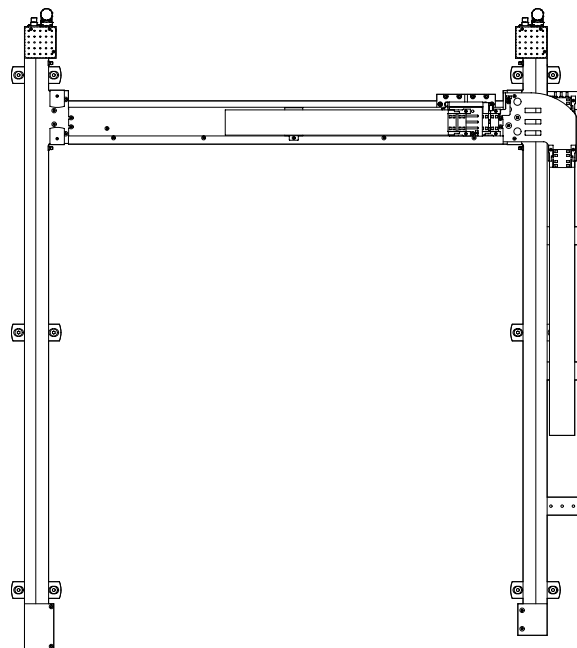

Note

During commissioning, the motor brake must be released for safety purposes.

Characteristics

Selection of attachment components (Z-axis)

Without attachment component

The following are already installed on delivery:

- [1] 2 compressed air supply ports for e.g. Z-axis
- [2] Multi-pin plug distributor (6-way) for bundling signals:
 - e.g. proximity sensors

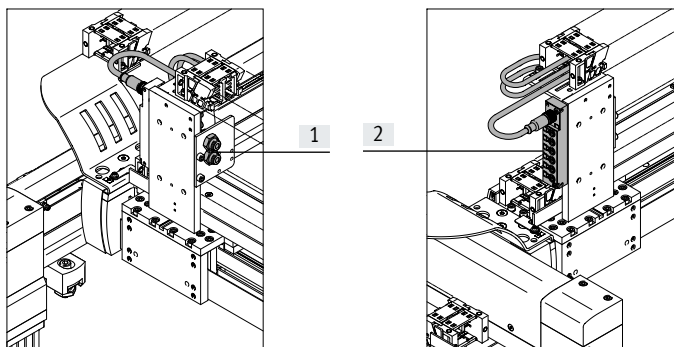

Attachment component, pneumatic (mini slide DGSL)

The following are already installed on delivery:

- [1] Solenoid valve for controlling the drive
- [2] 1 compressed air supply port for e.g. gripper
- [3] Multi-pin plug distributor (6-way) for bundling signals:
 - For mini slide DGSL:
 - 2 proximity sensors
 - 1 solenoid valve
 - 3 connections available
- [4] Proximity sensors for sensing the end positions

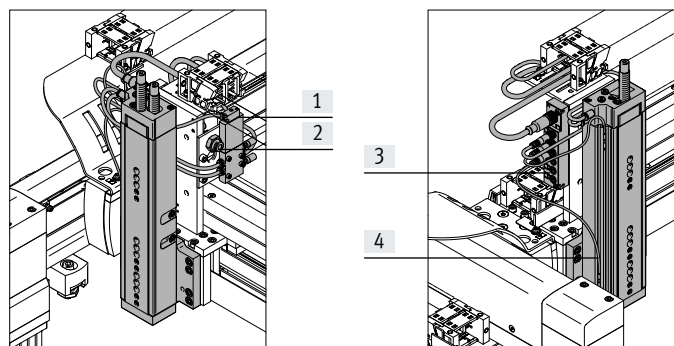

Attachment component, electric (mini slide EGSL)

The following are already installed on delivery:

- [1] 2 compressed air supply ports for e.g. gripper
- [2] Multi-pin plug distributor (6-way) for bundling signals:
 - e.g. proximity sensors

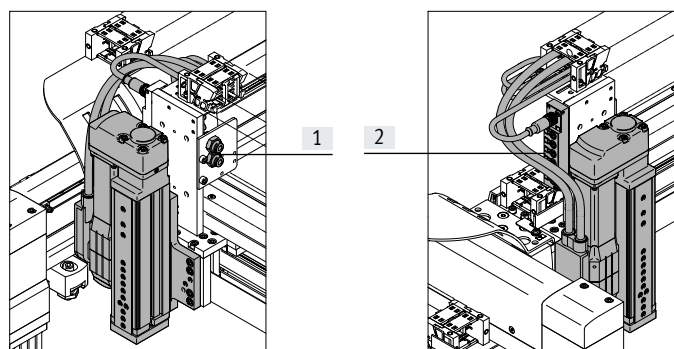

Additional information → page 16

Type codes

001	Series	
EXCH	Planar surface gantry	
002	Size	
40	40	
60	60	
003	Stroke of the X-axis [mm]	
200	200	
2500	2500	
004	Stroke of the Y-axis [mm]	
200	200	
1500	1500	
005	Guide	
KF	Recirculating ball bearing guide	
006	Motor type	
AB1	Servo motor AC, size 70, with brake	
AB2	Servo motor AC, size 100, with brake	
AB3	Servo motor AC, size 140, with brake	
AS1	Servo motor AC, size 70	
AS2	Servo motor AC, size 100	
AS3	Servo motor AC, size 140	
W	Without motor	
007	Motor attachment position	
B	Underneath	
T	Top	

008	Energy chain connection side	
L	Left	
009	Attachment components	
T0	None	
P1	Pneumatic lifting unit, stroke 50 mm	
P2	Pneumatic lifting unit, stroke 100 mm	
P3	Pneumatic lifting unit, stroke 150 mm	
P4	Pneumatic lifting unit, stroke 200 mm	
E1	Electric lifting unit, stroke 100 mm	
E2	Electric lifting unit, stroke 200 mm	
010	Cable length	
5K	5 m	
10K	10 m	
011	Mounting kit	
P	With mounting kit	
	With adjusting kit	
012	Document language	
DE	German	
EN	English	
ES	Spanish	
FR	French	
IT	Italian	
RU	Russian	
ZH	Chinese	

Peripherals overview

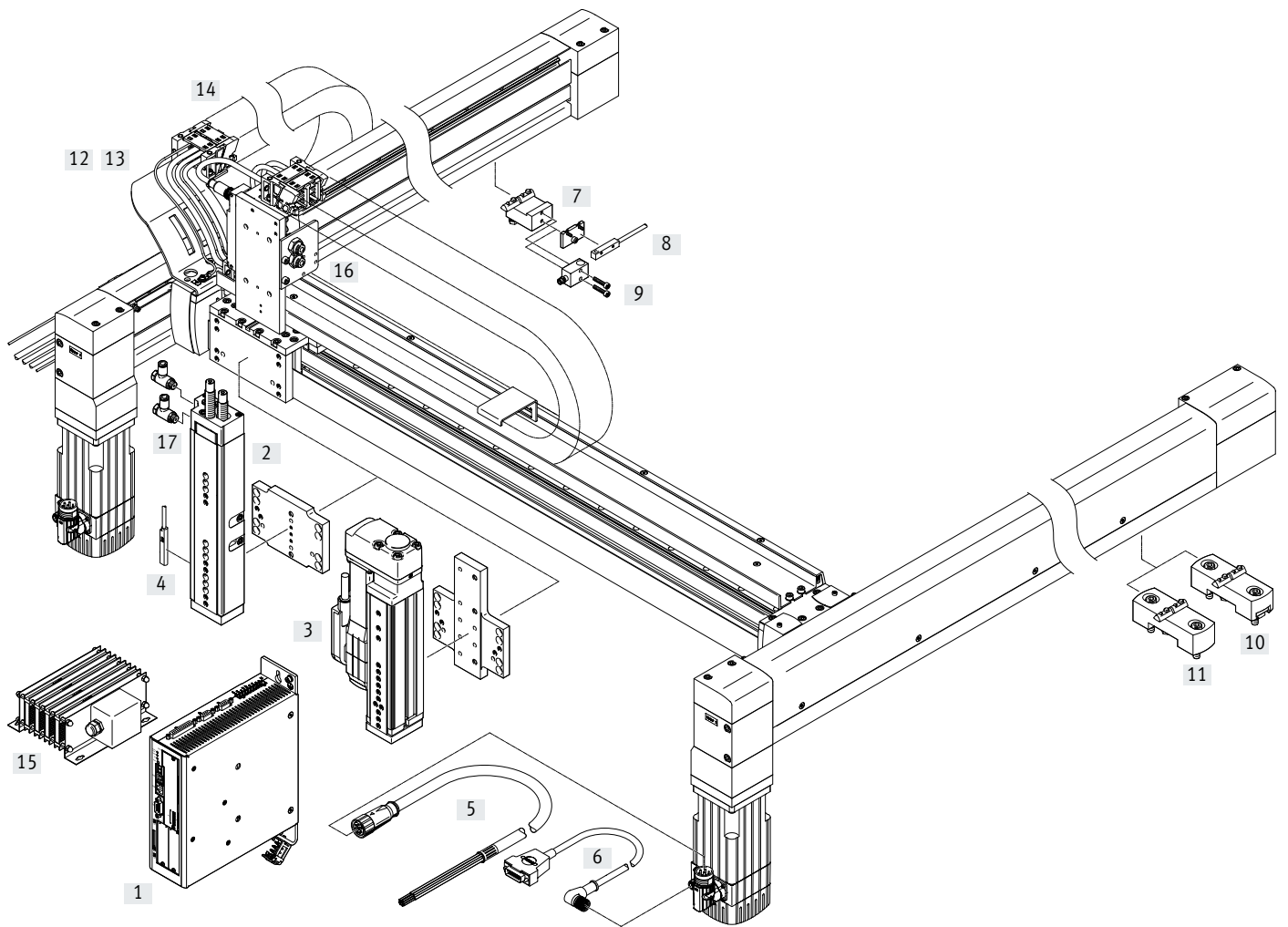

Proximity sensor for sensing the position of the slide on the Y-axis

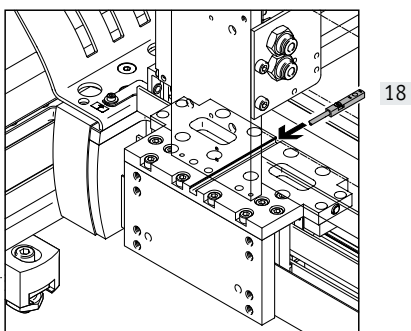

Peripherals overview

Attachments and accessories			
Type	Description		→ Page/Internet
[1] Motor controller CMMP-AS	<ul style="list-style-type: none"> For controlling the planar surface gantry 		34
[2] Mini slide P1, P2, P3, P4	<ul style="list-style-type: none"> Pneumatic attachment component (mini slide DGSL) for the Z-axis 		30
[3] Mini slide E1, E2	<ul style="list-style-type: none"> Electric attachment component (mini slide EGSL) with motor cable NEBM and encoder cable NEBM for the Z-axis 		30
[4] Proximity sensor SME-10M	<ul style="list-style-type: none"> For position sensing on the Z-axis Included in the scope of delivery of the planar surface gantry EXCH-...-P... 		33
[5] Motor cable NEBM-M23G8	<ul style="list-style-type: none"> Connecting cable between motor and motor controller CMMP-AS Included in the scope of delivery of the planar surface gantry EXCH-...-A... 		34
[6] Encoder cable NEBM-M12W8	<ul style="list-style-type: none"> Connecting cable between encoder and motor controller CMMP-AS Included in the scope of delivery of the planar surface gantry EXCH-...-A... 		34
[7] Sensor mounting EAPR	<ul style="list-style-type: none"> For mounting the proximity sensors SIES-Q8B and SIES-V3B on the X-axis Not included in the scope of delivery of the planar surface gantry 		32
[8] Proximity sensor SIES-Q8B	<ul style="list-style-type: none"> For position sensing on the X-axis Not included in the scope of delivery of the planar surface gantry 		33
[9] Proximity sensor SIES-V3B	<ul style="list-style-type: none"> For position sensing on the X-axis Not included in the scope of delivery of the planar surface gantry 		33
[10] Adjusting kit EADC-12	<ul style="list-style-type: none"> Height-adjustable mounting kit for the planar surface gantry Included in the scope of delivery of the planar surface gantry. If no adjusting kit is selected in the modular product system, the mounting kit will automatically be delivered 		32
[11] Mounting kit EAHM-E12	<ul style="list-style-type: none"> Non-height-adjustable mounting kit for the planar surface gantry 		32
[12] Multi-pin plug distributor NEDU	<ul style="list-style-type: none"> For connecting up to 6 inputs/outputs Included in the scope of delivery of the planar surface gantry 		nedu
[13] Plug socket with cable SIM	<ul style="list-style-type: none"> Connecting cable between multi-pin plug distributor NEDU and the controller Included in the scope of delivery of the planar surface gantry 		sim
[14] Energy chain	<ul style="list-style-type: none"> For EXCH-40: type IGUS E6.29.040.075.0 For EXCH-60: type IGUS E6.35.050.075.0 		-
[15] Braking resistor CACR-KL2	<ul style="list-style-type: none"> Essential in the case of a vertical mounting position 		33
[16] Plastic tubing PUN-H-6x1	<ul style="list-style-type: none"> Two compressed air tubes are connected to the bulkhead fittings and routed in the energy chains on delivery (for pneumatic Z-axis, one tube on the valve and one on the bulkhead fitting) 		pun
[17] One-way flow control valve GRLA	<ul style="list-style-type: none"> For regulating speed Included in the scope of delivery of the planar surface gantry EXCH-...-P... 		-
[18] Proximity sensor SIES-8M	<ul style="list-style-type: none"> For position sensing on the Y-axis Not included in the scope of delivery of the planar surface gantry 		33
Motor cable NEBM-T1G8	<ul style="list-style-type: none"> Connecting cable between motor on the Z-axis and motor controller CMMP-AS Included in the scope of delivery of the planar surface gantry EXCH-...-E... 		34
Encoder cable NEBM-T1G8	<ul style="list-style-type: none"> Connecting cable between encoder on the Z-axis and motor controller CMMP-AS Included in the scope of delivery of the planar surface gantry EXCH-...-E... 		34

Data sheet

Size
40, 60

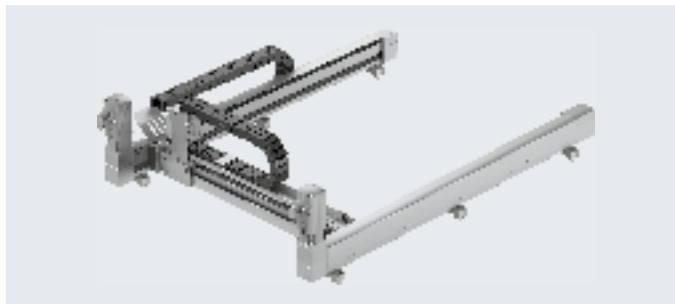

General technical data			
Size		40	60
Design	Planar surface gantry		
Guide	Recirculating ball bearing guide		
Stroke of the			
X-axis	[mm]	200 ... 2000	500 ... 2500
Y-axis	[mm]	200 ... 1000	500 ... 1500
Z-axis	[mm]	50, 100, 150, 200	
EXCH-...-E1	[mm]	100	
EXCH-...-E2	[mm]	200	
EXCH-...-P1	[mm]	50	
EXCH-...-P2	[mm]	100	
EXCH-...-P3	[mm]	150	
EXCH-...-P4	[mm]	-	
Rated load at max. dynamic response ¹⁾	[kg]	4	6
Max. torque ²⁾	[Nm]	→ Page 12	
Max. no-load torque ²⁾³⁾	[Nm]	→ Page 13	
Max. acceleration ⁴⁾			
Horizontal	[m/s ²]	50	
Vertical	[m/s ²]	30	
Max. speed ⁴⁾			
Horizontal	[m/s]	5	
Vertical	[m/s]	4	3
Repetition accuracy	[mm]	±0.1	
Mounting position ⁵⁾	Horizontal or vertical		
Type of mounting	Mounting kit, adjusting kit		

1) Rated load = tool load (attachment component (Z-axis) + gripper, for example) + payload

2) These values must also be complied with when installing third-party motors

3) At v=0.2 m/s and 45° travel.

4) These data apply only under ideal conditions.

For a precise configuration, please consult a sales engineer from Festo.

Additional information → page 13

5) Vertical installation only permitted with motors with brake and braking resistors

Factoring in software end positions

When selecting the strokes for the X- and Y-axis, the dimension L3 for the software end positions must be taken into account in addition to the working stroke L2. This dimension is freely selectable.

Setting pieces with L3 = 30 mm are included in the scope of delivery of the planar surface gantry.

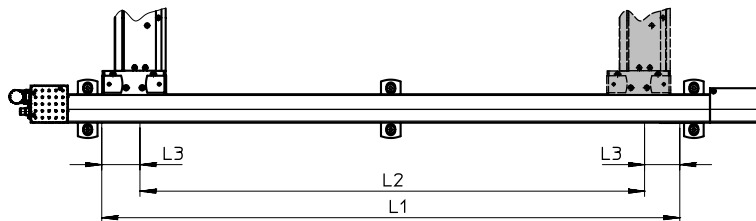

$$\text{Stroke } L1 = \text{working stroke } L2 + 2 \times \text{software end position } L3$$

Data sheet

Operating and environmental conditions		
Size		40 60
Degree of protection		IP40
Ambient temperature ¹⁾	[°C]	+10 ... +50
Storage temperature	[°C]	-10 ... +60
Relative humidity	[%]	0 ... 90 (non-condensing)
Sound pressure level	[dB(A)]	74 81
Duty cycle	[%]	100
CE marking (see declaration of conformity)		To EU Machinery Directive

1) Note operating range of proximity sensors and motors

Materials

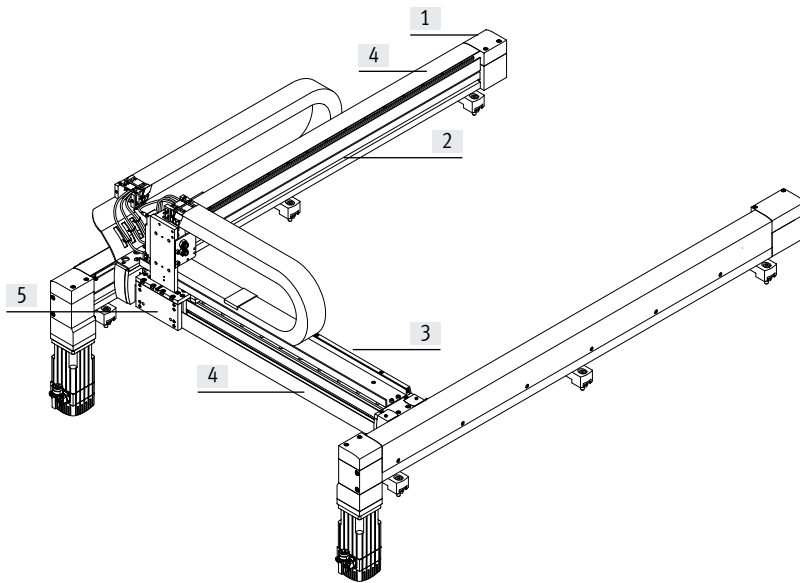

Size		
		40 60
[1]	Drive and end caps	Aluminium
[2]	Profiles of the X-axis	Aluminium
[3]	Profile of the Y-axis	Aluminium
[4]	Covering	
	X-axis	Aluminium
	Y-axis	Aluminium
[5]	Slide	Aluminium
-	Coupling	Aluminium with elastomer ring gear
		Clamping hub: aluminium Expanding mandrel hub: stainless steel Ring gear: elastomer
	Guide	Steel
	Drive pinion	Steel
	Ball bearing	Steel
	Toothed belt	PU with steel cord
	Note on materials	RoHS-compliant
		Contains paint-wetting impairment substances

Data sheet

Weights [kg]		
Size	40	60
Product weight with 0 mm stroke (without rated load, motors, axial kits, mounting kits)		
X-axis and Y-axis	16.6	37.9
Y-axis (without slide)	6.0	11.5
Additional weight per 100 mm stroke		
X-axis	1.69	2.21
Y-axis	0.81	0.99
Axial kit ¹⁾		
For EMMS-AS-70/-100	0.66	1.33
For EMMS-AS-100/-140	1.02	2.06
Motor ¹⁾		
Without brake		
EXCH-...-AS1	2.7	-
EXCH-...-AS2	4.8	6.9
EXCH-...-AS3	-	9.6
With brake		
EXCH-...-AB1	2.9	-
EXCH-...-AB2	5.3	7.5
EXCH-...-AB3	-	10.4
Attachment component (Z-axis)		
Electric		
EXCH-...-E1	3.4	5.3
EXCH-...-E2	4.0	6.2
Pneumatic		
EXCH-...-P1	1.8	2.7
EXCH-...-P2	2.4	3.6
EXCH-...-P3	2.7	4.3
EXCH-...-P4	-	5.0
Mounting kit for X-axis		
Adjusting kit ¹⁾	0.78	0.89
Mounting kit ¹⁾	0.33	0.37

1) Weight per component

Data sheet

Acceleration a as a function of the rated load m and stroke of the Y-axis

The following data apply to a horizontal mounting position. For a vertical mounting position, please get in touch with your local contact at Festo.

The centre of gravity of the slide is at the height of the slide in the Z-direction and in the centre of the slide in the X-/Y-directions.

EXCH-40

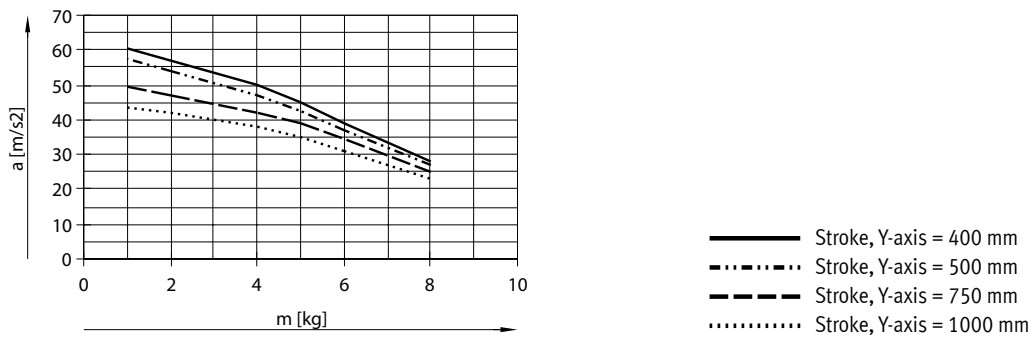

EXCH-60

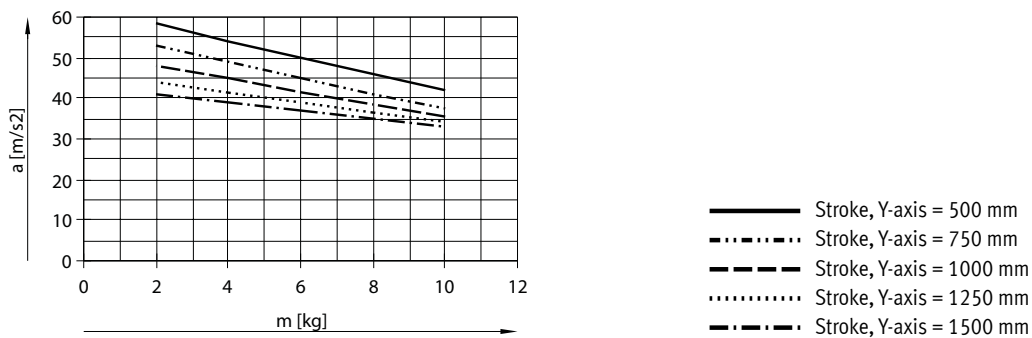

Data sheet

Torque M as a function of rotational speed n

Typical motor characteristic curve with nominal voltage and optimal motor controller. The torque may briefly exceed the nominal torque. The rms value of the torque for the particular positioning cycle must remain below the nominal torque.

The "Handling Guide Online" tool can be used to configure the planar surface gantry with other combinations (motor/motor controller).

EXCH-40

In combination with:
EMMS-AS-70-M-LS-RM, EMMS-AS-70-M-LS-RMB
and CMMP-AS-C5-3A

In combination with:
EMMS-AS-100-S-HS-RM, EMMS-AS-100-S-HS-RMB
and CMMP-AS-C5-11A

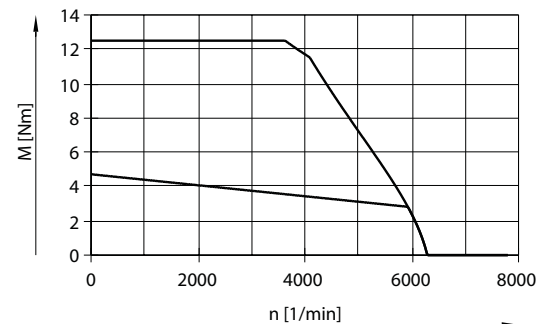
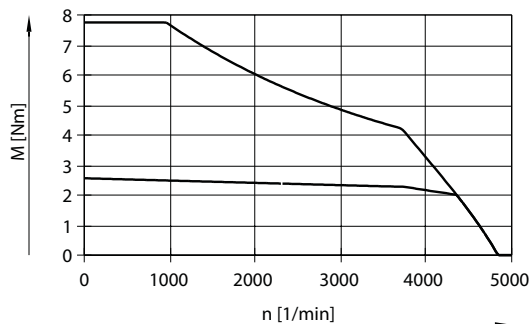

— Max. torque
- - - - - Nominal torque

— Max. torque
- - - - - Nominal torque

EXCH-60

In combination with:
EMMS-AS-100-M-HS-RM, EMMS-AS-100-M-HS-RMB
and CMMP-AS-C5-11A

In combination with:
EMMS-AS-140-S-HV-RM, EMMS-AS-140-S-HV-RMB
and CMMP-AS-C5-11A

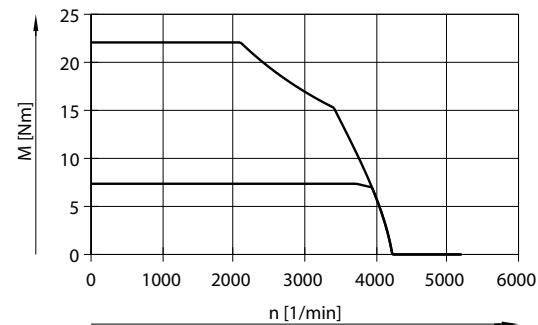
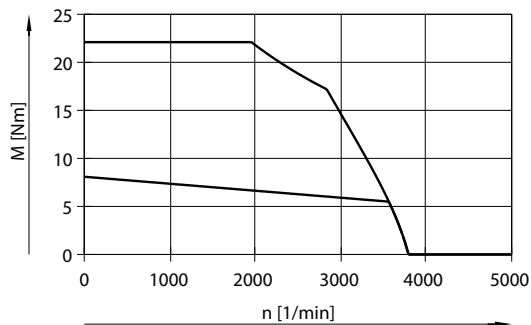

— Max. torque
- - - - - Nominal torque

— Max. torque
- - - - - Nominal torque

Data sheet

No-load torque M as a function of rotational speed n

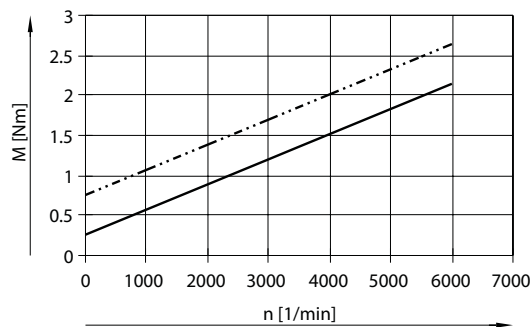

— EXCH-40
 - - - EXCH-60

Characteristic load values

The following data apply to a horizontal mounting position. For a vertical mounting position, please get in touch with your local contact at Festo.

The system is subject to the greatest load in the case of 45° travel. The following data apply in this case:

Formula for calculating the required torque M and the required nominal rotational speed n

For EXCH-40:

$$M_{45^\circ} = a \times (9.79 \times m_L + 4.89 \times m_{Ay} + 10.21 \times J_m + 19.58) \times 10^{-3} + M_R$$

$$n_{45^\circ} = 975 \times v$$

For EXCH-60:

$$M_{45^\circ} = a \times (14.07 \times m_L + 7.03 \times m_{Ay} + 7.11 \times J_m + 49.24) \times 10^{-3} + M_R$$

$$n_{45^\circ} = 679 \times v$$

a = acceleration [m/s²]

v = speed [m/s]

m_{Ay} = product weight of the Y-axis [kg] → page 10

m_L = attachment component (Z-axis) [kg] with payload

J_m = moment of inertia of the motor [kgcm²] → table below

M_R = no-load torque [Nm] → page 13

n_{45° = nominal rotational speed at 45° travel [rpm]

Allocation of planar surface gantry to servo motor for X-/Y-axis

Planar surface gantry	Motor	Moment of inertia of motor [kgcm ²]
EXCH-40-...-AB1	EMMS-AS-70-M-LS-RMB	0.68
EXCH-40-...-AS1	EMMS-AS-70-M-LS-RM	0.611
EXCH-40-...-AB2 ¹⁾	EMMS-AS-100-S-HS-RMB	3.085
EXCH-40-...-AS2	EMMS-AS-100-S-HS-RM	2.529
EXCH-60-...-AB2	EMMS-AS-100-M-HS-RMB	5.285
EXCH-60-...-AS2	EMMS-AS-100-M-HS-RM	4.729
EXCH-60-...-AB3 ¹⁾	EMMS-AS-140-S-HV-RMB	9.271
EXCH-60-...-AS3	EMMS-AS-140-S-HV-RM	8.189

1) Essential when the planar surface gantry is mounted vertically.

Data sheet

Example calculation

Given:

Planar surface gantry

EXCH-40-1000-500-KF-AS2-B-L-E1-...

with attached motor

EMMS-AS-100-S-HS-RMB

$$a_{\max} = 25 \text{ m/s}^2$$

$$v_{\max} = 2 \text{ m/s}$$

$$\text{Payload} = 0.5 \text{ kg}$$

Attachment component on Z-axis: EGSL-BS-45-100-10P

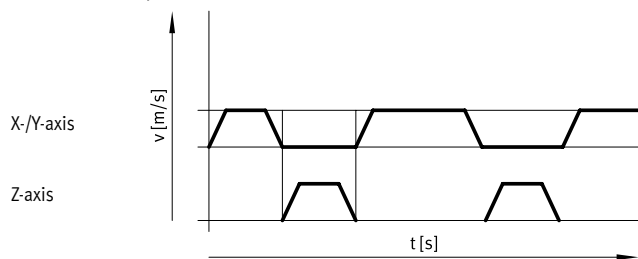

Calculation:

1. What is the max. acceleration permitted by the mechanical system?

Moving mass m_L on the Y-axis:

Z-axis 3.40 kg

Payload 0.50 kg
= 3.90 kg

Stroke of the Y-axis:

500 mm

Result:

In the case of a moving mass m_L of 3.9 kg, the maximum permissible acceleration is 46 m/s^2 .

The required acceleration of 25 m/s^2 is thus permissible.

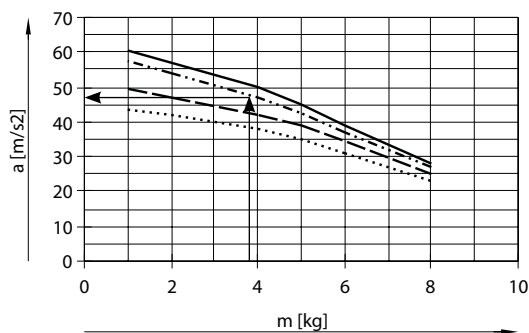

- Stroke, Y-axis = 400 mm
- Stroke, Y-axis = 500 mm
- - - Stroke, Y-axis = 750 mm
- · - · Stroke, Y-axis = 1000 mm

Note

The following data apply to a horizontal mounting position. For a vertical mounting position, please get in touch with your local contact at Festo.

The centre of gravity of the slide is at the height of the slide in the Z-direction and in the centre of the slide in the X-/Y-directions.

Data sheet

Example calculation

2. Is the attached motor sufficient for this load?

Given: $M_{45^\circ} = a \times (9.79 \times m_L + 4.89 \times m_{Ay} + 10.21 \times J_m + 19.58) \times 10^{-3} + M_R$
 $n_{45^\circ} = 975 \times v$

$a_{\max} = 25 \text{ m/s}^2$
 $v_{\max} = 2 \text{ m/s}$
 $m_{Ay} = 10.05 \text{ kg}$
 $m_L = 3.90 \text{ kg}$
 $J_m = 3.085 \text{ kgcm}^2$

$a =$ acceleration [m/s^2]
 $v =$ speed [m/s]
 $m_{Ay} =$ product weight of the Y-axis [kg] → page 10
 $m_L =$ attachment component (Z-axis) [kg] with payload
 $J_m =$ moment of inertia of the motor [kgcm^2] → table below
 $M_R =$ no-load torque [Nm] → page 13
 $n_{45^\circ} =$ nominal rotational speed at 45° travel [rpm]

**Note**

These requirements for the dynamic response apply to 45° travel.

The dynamic values may be higher for travel only in the X- or Y-direction.

Determining M_{45°

$$n_{45^\circ} = 975 \times 2 \text{ ms} = 1950 \text{ rpm}$$

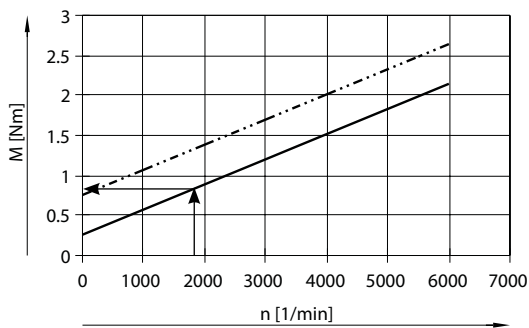

No-load torque:

— EXCH-40
 - - - EXCH-60

$$M_R = 0.9 \text{ Nm}$$

$$M_{45^\circ} = a \times (9.79 \times m_L + 4.89 \times m_{Ay} + 10.21 \times J_m + 19.58) \times 10^{-3} + M_R$$

$$M_{45^\circ} = 25 \text{ m/s}^2 \times (9.79 \times 3.9 \text{ kg} + 4.89 \times 10.05 \text{ kg} + 10.21 \times 3.085 \text{ kgcm}^2 + 19.58) \times 10^{-3} + 0.9 \text{ Nm} = 4.36 \text{ Nm}$$

Result:

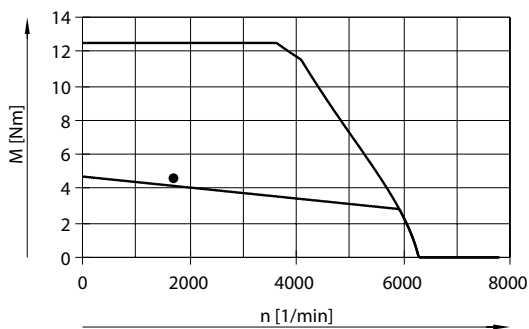

— Max. torque
 - - - Nominal torque

The value for the torque is above the nominal torque and below the maximum torque.

This torque is only required in the acceleration phases.

The rms value of the torque for the particular positioning cycle must remain below the nominal torque.

Data sheet

Selection of attachment components

The following variants for the Z-axis can optionally be selected using the modular product system

→ page 30:

- Without attachment component
- With pneumatic attachment component (mini slide DGSL)
- With electric attachment component (mini slide EGSL)

The drives are fully connected on delivery. Cables and tubes are routed as far as the output of the energy chain (X-axis).

EXCH-...-T0... (without attachment component)

The following are pre-installed:

- 2 compressed air supply ports for e.g. Z-axis
- Multi-pin plug distributor for bundling signals:
 - e.g. proximity sensors

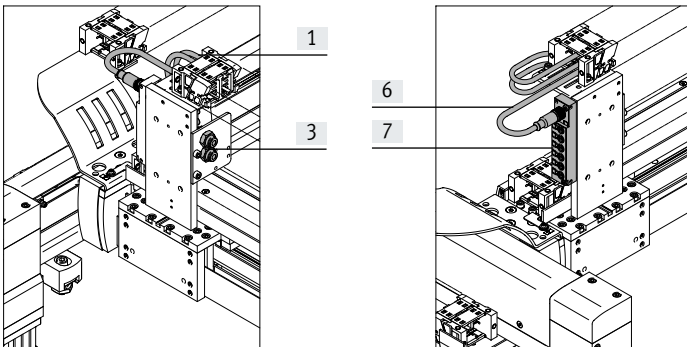

Components	Number of components
[1] Compressed air tubing	2
[3] Bulkhead fitting	2
[6] Plug socket with cable	1
[7] Multi-pin plug distributor (6-way)	1
– Earthing cable	2

EXCH- ... -P... (pneumatic attachment component)

The following are pre-installed:

- Solenoid valve for controlling the drive
- 1 compressed air supply port for e.g. gripper
- Proximity sensors for sensing the end positions
- Multi-pin plug distributor for bundling signals:
 - For mini slide DGSL:
 - 2 proximity sensors
 - 1 solenoid valve
 - 3 connections available

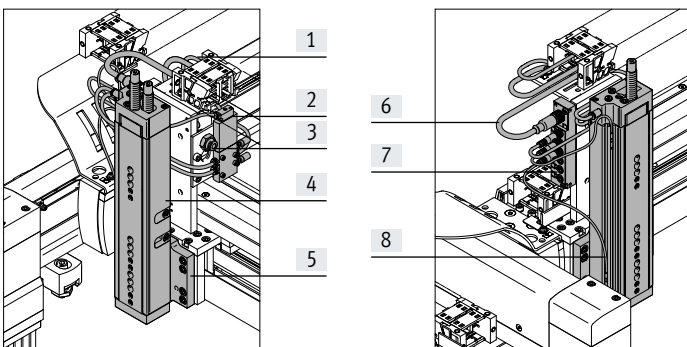

Components	Number of components
[1] Compressed air tubing	2
[2] Solenoid valve	1
[3] Bulkhead fitting	1
[4] Mini slide DGSL-...-Y3A ¹⁾	1
[5] Adapter plate	1
[6] Plug socket with cable	1
[7] Multi-pin plug distributor (6-way)	1
[8] Proximity sensor	2
– Earthing cable	2

1) For EXCH-40, the mini slide DGSL-16 is used with progressive shock absorbers.

For EXCH-60, the mini slide DGSL-20 is used with progressive shock absorbers.

Additional information → Internet: dgs1

Data sheet

Selection of attachment components

EXCH-...-E... (electric attachment component)

The following are pre-installed:

- 2 compressed air supply ports for e.g. gripper
- Multi-pin plug distributor for bundling signals:
 - e.g. proximity sensors

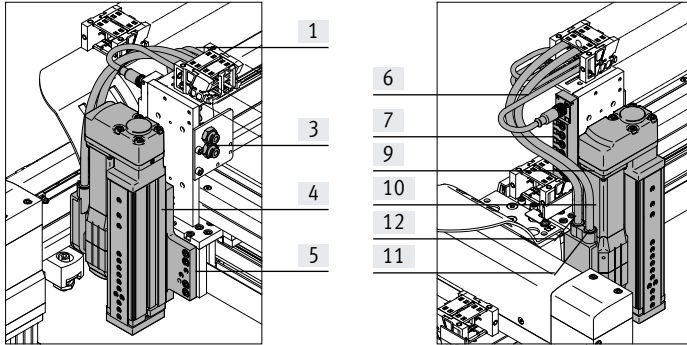

Components	Number of components
[1] Compressed air tubing	2
[3] Bulkhead fitting	2
[4] Mini slide EGSL ¹⁾	1
[5] Adapter plate	1
[6] Plug socket with cable	1
[7] Multi-pin plug distributor (6-way)	1
[9] Parallel kit	1
[10] Motor	1
[11] Motor cable	1
[12] Encoder cable	1
– Earthing cable	2

1) For EXCH-40, the mini slide EGSL-45 is used with a pitch of 10 mm.
 For EXCH-60, the mini slide EGSL-55 is used with a pitch of 12.7 mm.
 Additional information → Internet: egsl

Mounting position of the Z-axis

Due to manufacturing tolerances and the backlash in the guides, the angle between the X- and Z-axes may not be exactly 90° in certain circumstances.
 Max. deviation:

EXCH-40: $\alpha = \pm 1.1^\circ$

EXCH-60: $\alpha = \pm 2.1^\circ$

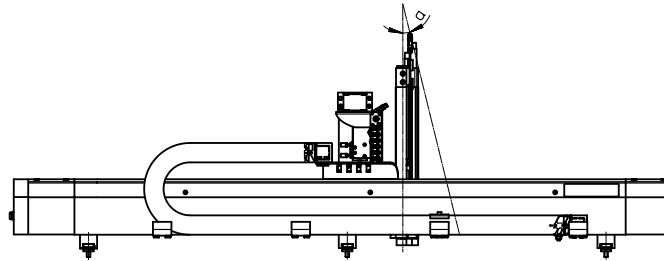

Selection of cable lengths

2 cable lengths (5 m or 10 m) can be selected using the modular product system → page 30. This specification relates to the output of the energy chain at the X-axis (dimension L) and describes the minimum length by which the cables and tubing protrude. The selected length applies to the following components:

- Compressed air tubing
- Plug sockets with cable
- Motor cables
- Encoder cables
- Earthing cables

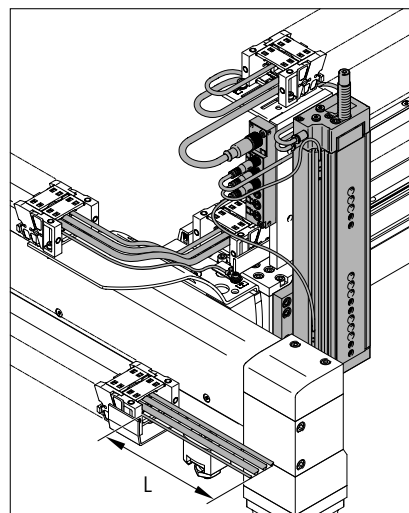

Data sheet

Number of profile mountings

Irrespective of the mounting position, a different number of profile mountings needs to be used depending on the stroke of the X-axis.

The required number is mounted on delivery.

Stroke of the X-axis [mm]	Number of profile mountings per axis	
	EXCH-40	EXCH-60
200 ... 499	2	-
500 ... 899	2	-
900 ... 1799	3	-
1800 ... 2000	4	-
2000 ... 2500	-	4

Distances between the profile mountings

The profile mountings must be evenly spaced by distance l_1 .

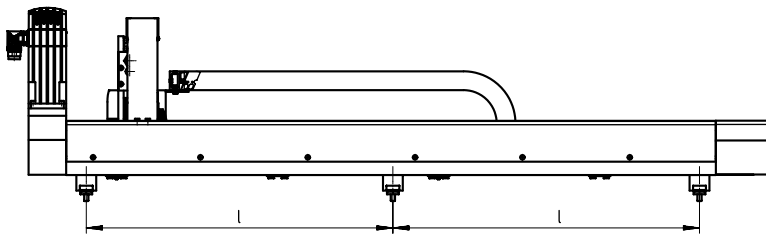

For EXCH-40

For EXCH-60

$$l_1 = \frac{l + 141}{n - 1}$$

$$l_1 = \frac{l + 328}{n - 1}$$

l_1 = distance

l = stroke

n = number of profile mountings per axis

Data sheet

Pin allocations

Motors on the X-/Y-axis

Motor (M23, pins)



PIN	Function	Colour
1	U Phase U	BK (1)
PE	PE Protective earthing	GNYE
3	W Phase W	BK (3)
4	V Phase V	BK (2)
A	M ₁₊ Temperature sensor	WH
B	M ₁₋ Temperature sensor	BN
C	BR ₊ Brake	GN
D	BR ₋ Brake	YE

Motor on the Z-axis

Motor

Black plug

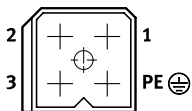

PIN	Function	Colour
1	V Phase	BK (2)
2	W Phase	BK (3)
3	U Phase	BK (1)
PE	PE Protective earthing	GNYE

Encoder

Red plug

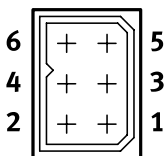

PIN	Function
1	DATA
2	DATA/
3	0 V
4	UP
5	CLOCK/
6	CLOCK

Encoder (M12, pins)

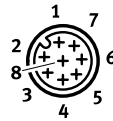

PIN	Function
1	-SENS
2	+SENS
3	DATA
4	DATA/
5	0 V
6	CLOCK/
7	CLOCK
8	UP

Temperature sensor and brake

Blue plug

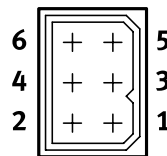

PIN	Function	Colour
1	M ₁₊ Temperature sensor	WH
2	M ₁₋ Temperature sensor	BN
3	BR ₊ Brake	GN
4	BR ₋ Brake	YE
5	n.c.	-
6	n.c.	-

Encoder

Yellow plug

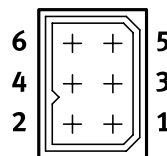

PIN	Function
1	-SENS
2	+SENS
3	n.c.
4	n.c.
5	n.c.
6	n.c.

Data sheet

Dimensions

Download CAD data → www.festo.com

EXCH-40-...-T – Motor mounting position on top

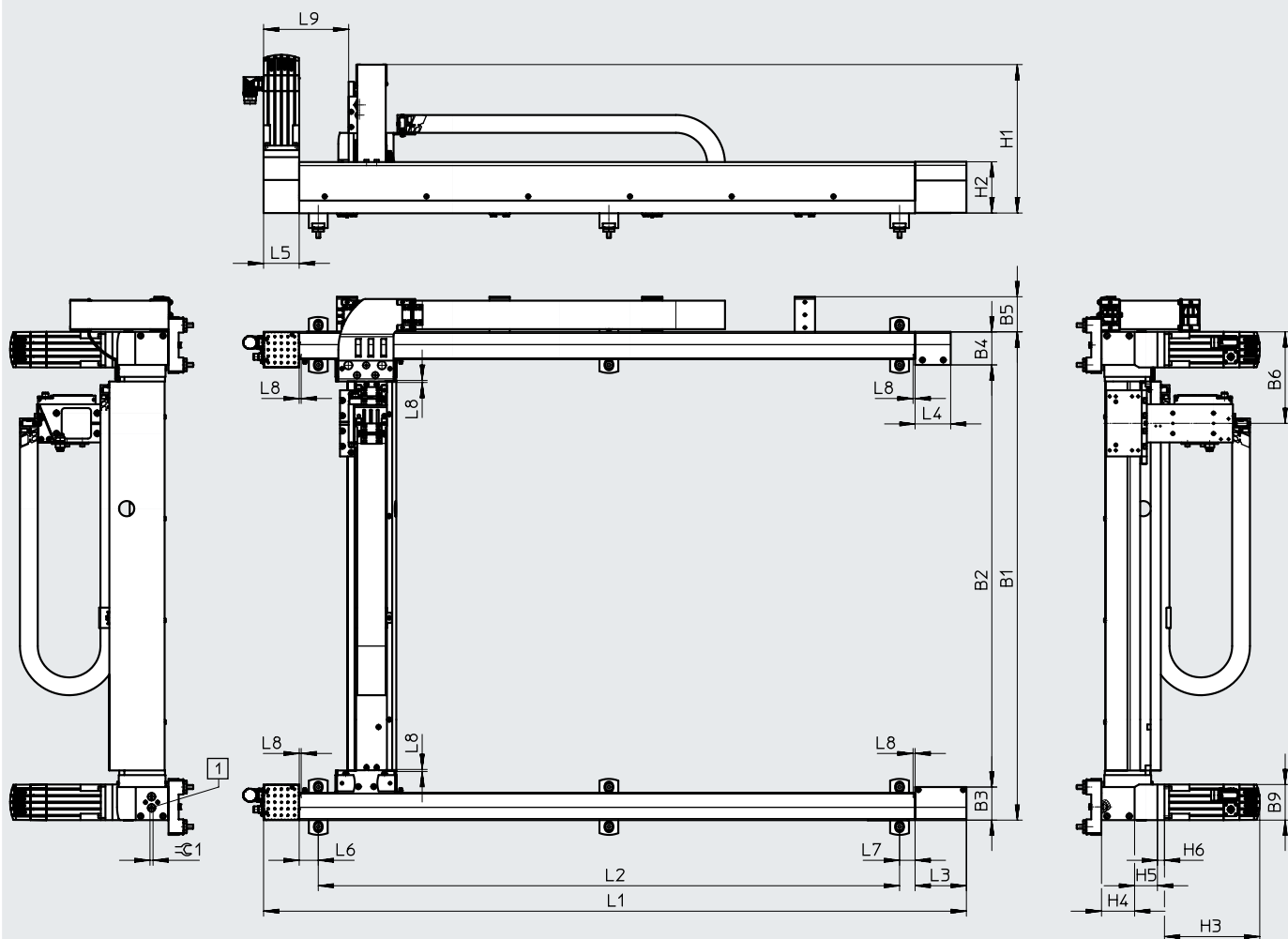

[1] Screw for toothed belt tension

L8 Safety distance per side

EXCH-40-...-B – Motor mounting position underneath

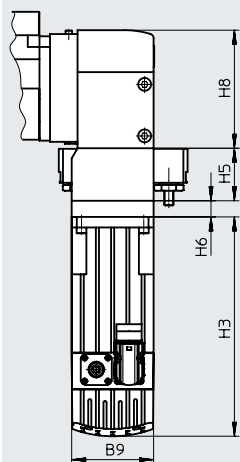

EXCH-40-... – Motor interface

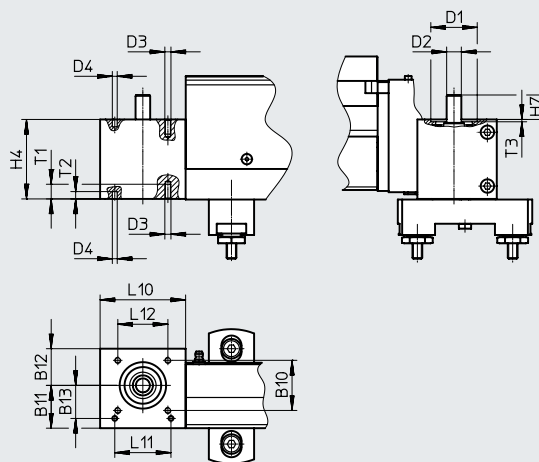

Data sheet

Dimensions

Download CAD data → www.festo.com

EXCH-40-... – Slide

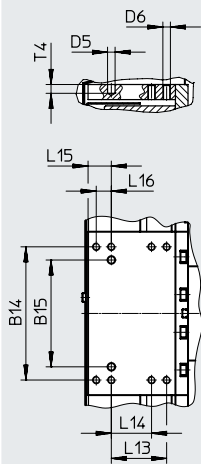

Type	B3	B4	B5	B6	B9	B10	B11	B12	B13	B14
									±0.05	±0.1
With EMMS-AS-70	65	65	69	179.9	70	41	35	30	27	106
With EMMS-AS-100	65	65	69	179.9	100.5					

Type	B15	D1	D2	D3	D4	D5	D6	H1	H2	H3
	±0.03	∅ H7	∅ h6		∅ H7	∅ H7				
With EMMS-AS-70	85	38	12	M5	4	6	M6	Approx. 293	100.8	187.3
With EMMS-AS-100										192.3

Type	H4	H5	H6	H7	H8	L3	L4	L5	L6	L7	L8	L9
With EMMS-AS-70	65	44.9	13.8	20	100.3	101	70	70	37.5	30.5	4	167.2
With EMMS-AS-100		57	20.1									

Type	L10	L11	L12	L13	L14	L15	L16	T1	T2	T3	T4	≙C1
		±0.03		±0.1	±0.1		±0.1					
With EMMS-AS-70	70	46	41	44	32	18.5	12	12	6	1.9	7	6
With EMMS-AS-100												

Stroke-dependent dimensions											
Stroke of the X-axis	L1		L2		Stroke of the Y-axis	B1		B2			
500	882		641		400	760		630			
750	1132		891		500	860		730			
1000	1382		1141		750	1100		980			
1500	1882		1641		1000	1360		1230			
200 ... 2000	382+stroke		→ Page 18		200 ... 1000	360+stroke		230+stroke			

 **Note**

Depending on the stroke of the X-axis, a different number of profile mountings is required. The distance between the profile mountings must always be the same (→ page 18).

The tension of the toothed belt must be set before commissioning. The tools required to do this (e.g. frequency meter) are not included in the scope of delivery.

Data sheet

Dimensions

Download CAD data → www.festo.com

EXCH-60-...T – Motor mounting position on top

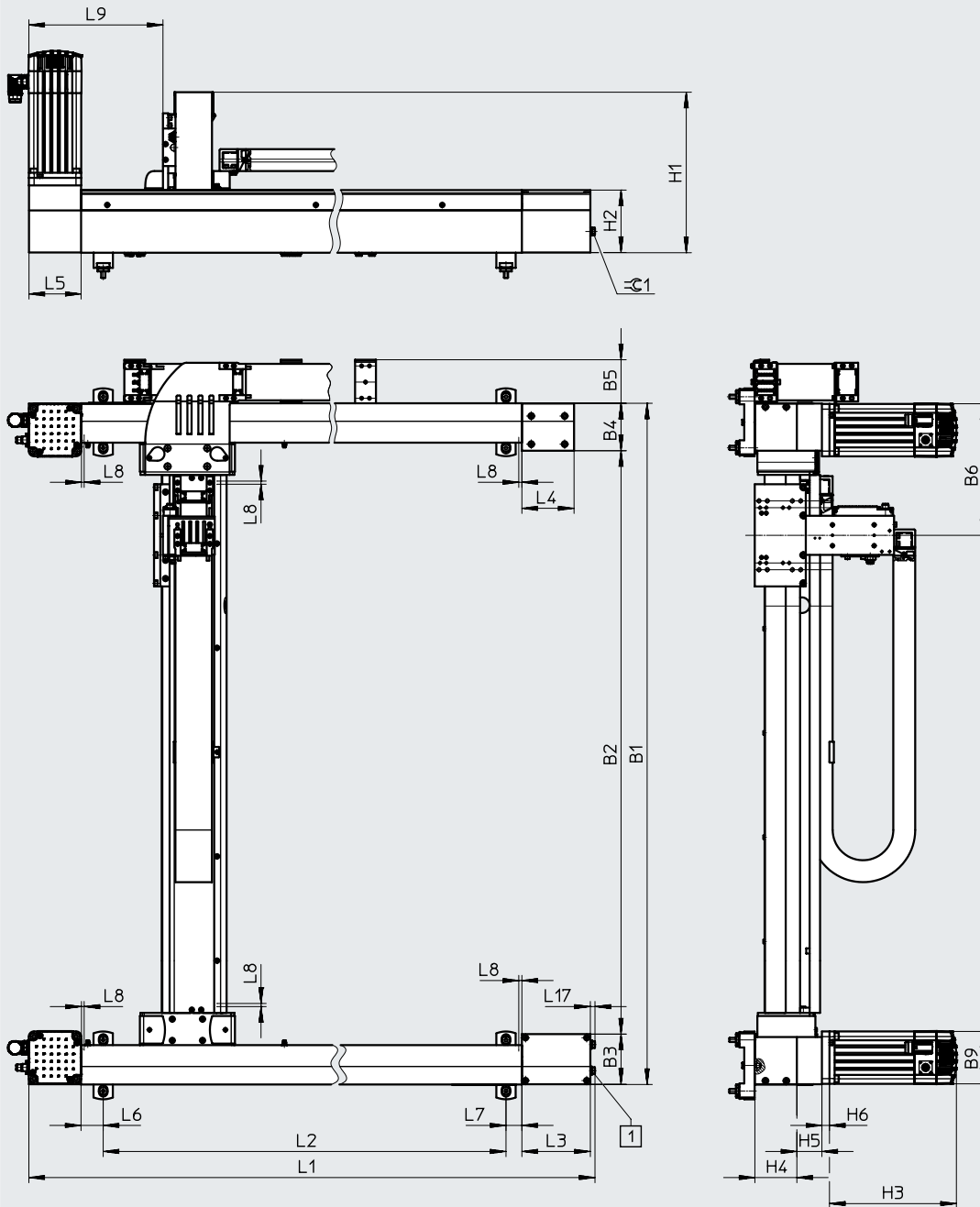

- [1] Screw for toothed belt tension
- L8 Safety distance per side

Data sheet

Type	B3	B4	B5	B6	B9	H1
With EMMS-AS-100	96.6	91	83.5	253.3	100.5	Approx. 310
With EMMS-AS-140					140.5	

Type	H2	H3	H4	H5	H6	L3	L4
With EMMS-AS-100	120.1	243.3	80.6	48	14.5	131.2	100
With EMMS-AS-140		209			24.5		

Type	L5	L6	L7	L8	L9	L17	≙1
With EMMS-AS-100	100	42.5	30.5	6	257	8.9	13
With EMMS-AS-140							

Stroke-dependent dimensions					
Stroke of the X-axis	L1	L2	Stroke of the Y-axis	B1	B2
750	1393	1078	500	1007	819
1000	1643	1328	750	1257	1069
1500	2143	1828	1000	1507	1319
2000	2643	2328	1250	1757	1569
500 ... 2500	643 + stroke	→ Page 18	1500	2007	1819
			500 ... 1500	507 + stroke	319 + stroke

**Note**

Depending on the stroke of the X-axis, a different number of profile mountings is required. The distance between the profile mountings must always be the same (→ page 18).

The tension of the toothed belt must be set before commissioning. The tools required to do this (e.g. frequency meter) are not included in the scope of delivery.

Data sheet

Dimensions

Download CAD data → www.festo.com

EXCH-60-...-B – Motor mounting position underneath

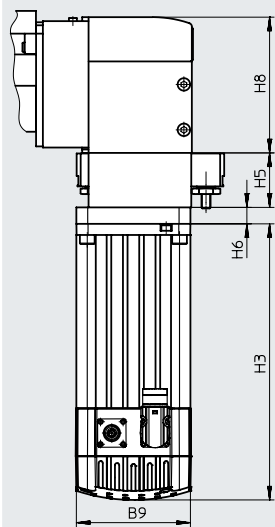

EXCH-60-... – Motor interface

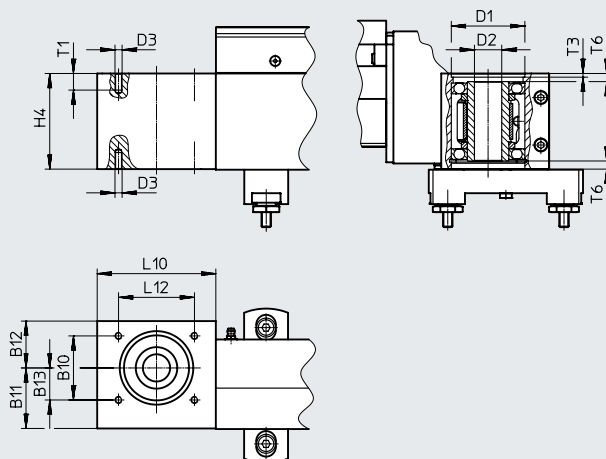

EXCH-60-... – Slide

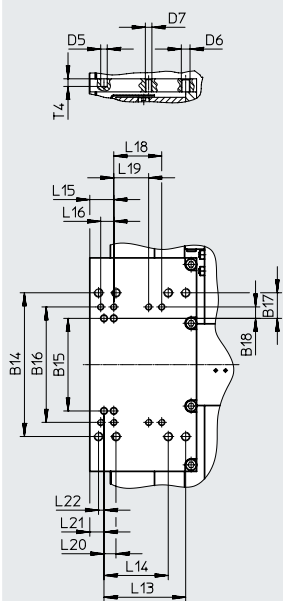

Type	B9	B10	B11	B12	B13	B14	B15	B16	B17	B18	D1	D2
		±0.1			±0.05	±0.1	±0.03	±0.1	±0.1	±0.1	∅ H7	∅ H7
With EMMS-AS-100	100.5	54	51	39.5	27	132	85	106	23.5	10.5	62	23
With EMMS-AS-140	140.5											

Type	D3	D5	D6	D7	H3	H4	H5	H6	H8	L10	L12	L13
		∅ H7									±0.1	±0.1
With EMMS-AS-100	M6	6	M8	M6	243.3	80.6	48	14.5	119.6	100	64	75
With EMMS-AS-140					209			24.5				

Type	L14	L15	L16	L18	L19	L20	L21	L22	T1	T3	T4	T6
	±0.1		±0.1	±0.1	±0.1	±0.1						
With EMMS-AS-100	59	22	12	44	32	11	13	5	14	3.1	7	6.9
With EMMS-AS-140												

Data sheet

Dimensions

Download CAD data → www.festo.com

EXCH-40-...-P...

With pneumatic attachment component (mini slide DGSL)

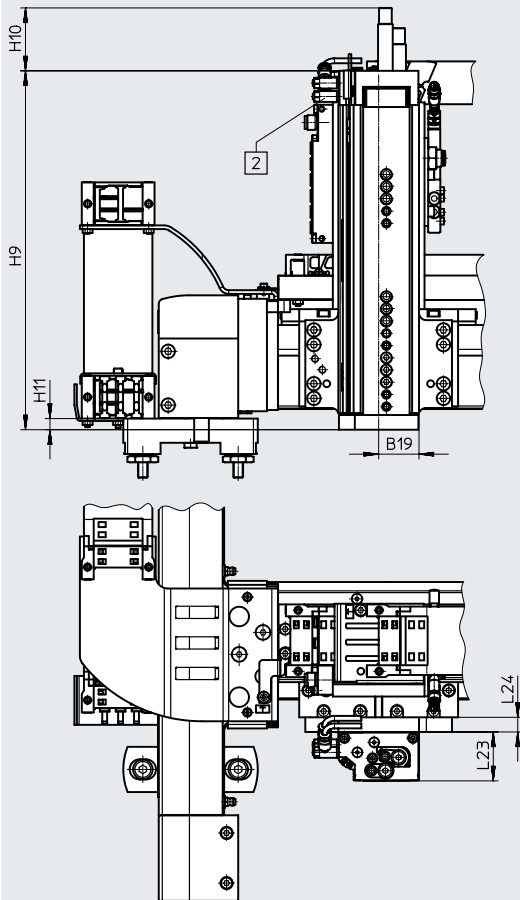

EXCH-40-...-E...

With electric attachment component (mini slide EGSL)

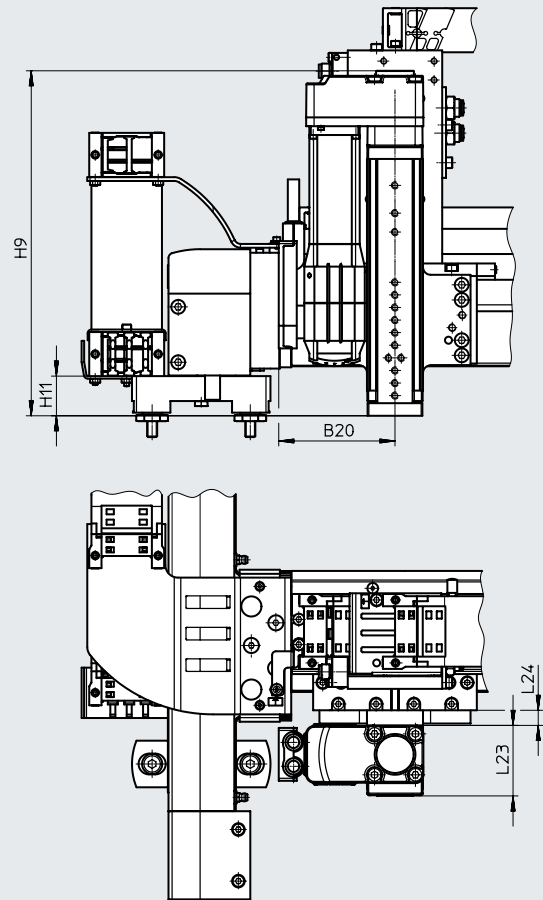

[2] One-way flow control valves are included in the scope of delivery.

Type	B19	B20	H9	H10 max.	H11	L23	L24
With pneumatic attachment component (mini slide DGSL)							
EXCH-40-...-P1	33	–	164.6	51.9	9.1	40±0.08	12
EXCH-40-...-P2			243.6				
EXCH-40-...-P3			293.6				
With electric attachment component (mini slide EGSL)							
EXCH-40-...-E1	–	92.3	274	–	31.5	56	12
EXCH-40-...-E2			374				

Data sheet

Dimensions

Download CAD data → www.festo.com

EXCH-60-...-P...

With pneumatic attachment component (mini slide DGSL)

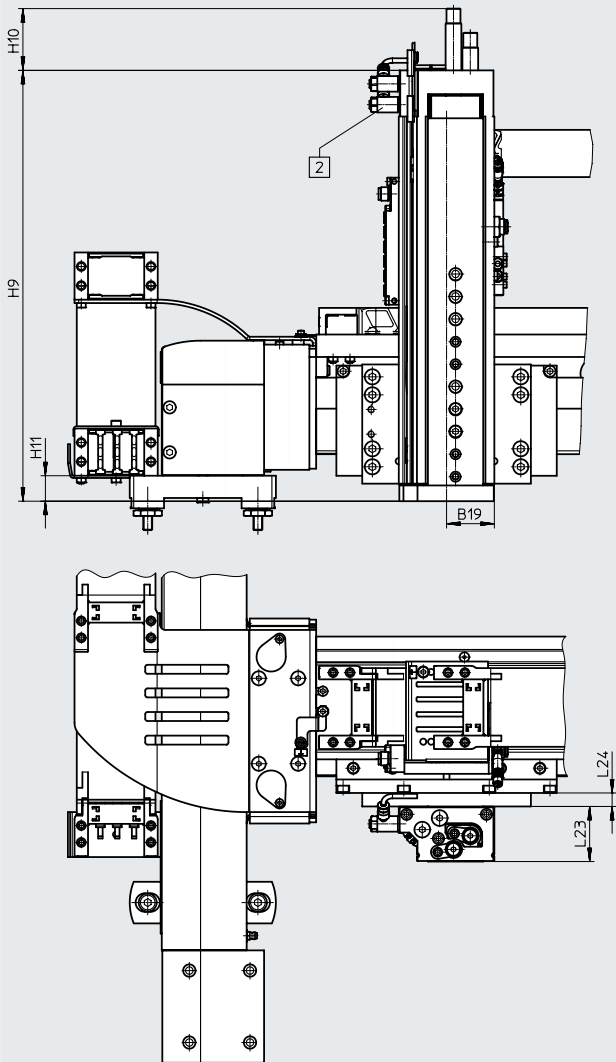

[2] One-way flow control valves are included in the scope of delivery.

Type	B19	H9	H10 max.	H11	L23 ±0.08	L24
EXCH-60-...-P1	42.5	183.2	55.5	22.7	49	12
EXCH-60-...-P2		270.2				
EXCH-60-...-P3		333.2				
EXCH-60-...-P4		383.2				

Data sheet

Dimensions

Download CAD data → www.festo.com

EXCH-60-...-E...

With electric attachment component (mini slide EGSL)

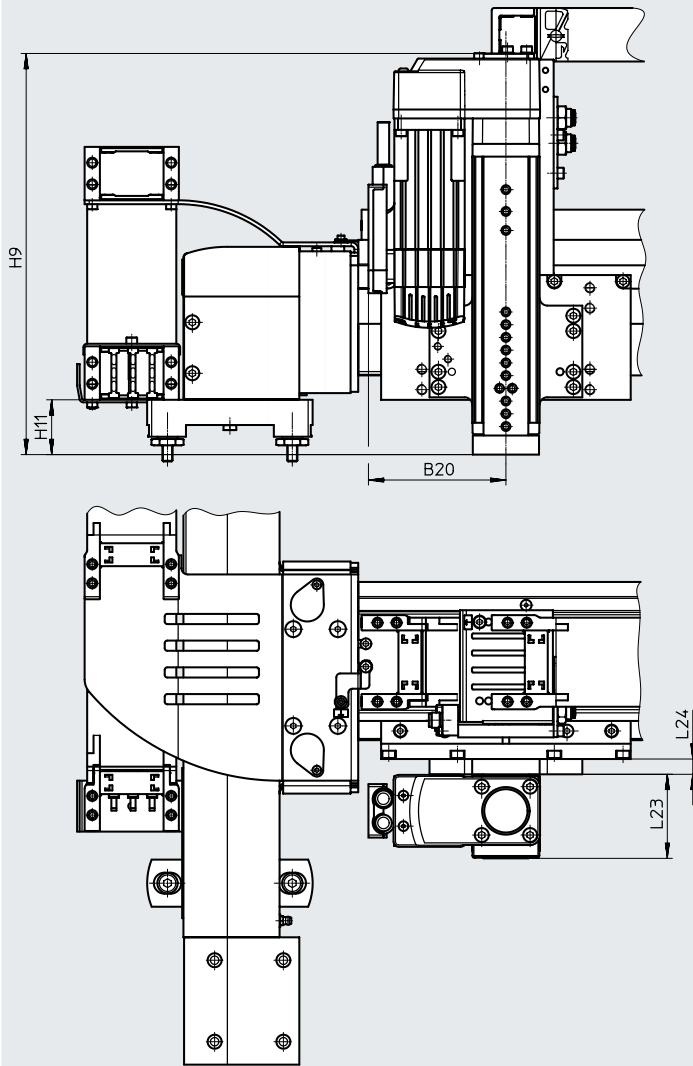

Type	B20	H9	H11	L23	L24
EXCH-60-...-E1	108	315	43	66	12
EXCH-60-...-E2		415			

Data sheet

Dimensions

Download CAD data → www.festo.com

Adjusting kit EADC

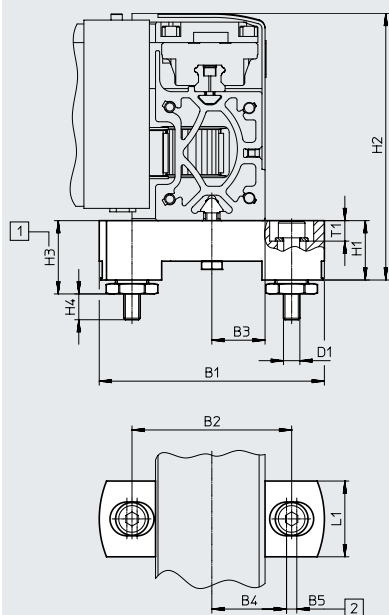

[1] Adjustable
 [2] Width of elongated hole
 Height differences of up to 5 mm can be compensated using the adjusting kit.
 Can be ordered via:
 Modular product system → page 30
 or accessories → page 32

For size	B1	B2	B3	B4 ±0.2	B5	D1	H1	H2	H3		H4 max.	L1	T1
									min.	max.			
40	110	78	26	36.5	5	M8	29	129.8	34.8	39.8	14	37	10
60	130	98	36.5	46.5	5	M8	29	149.1	34.8	39.8	14	37	10

Mounting kit

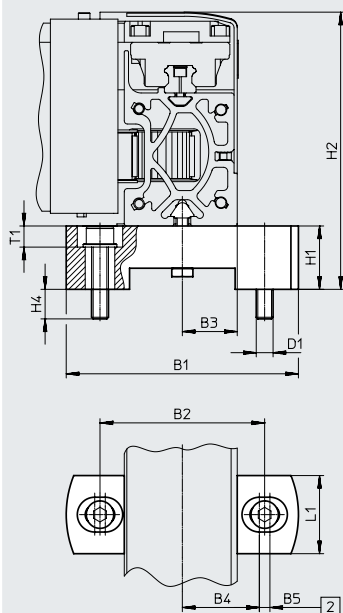

[2] Width of elongated hole
 No compensation is possible using the mounting kit.
 Can be ordered via:
 Modular product system → page 30
 or accessories → page 32

For size	B1	B2	B3	B4 ±0.2	B5	D1	H1 +0.2	H2	H4 max.	L1	T1
40	110	78	26	36.5	5	M8	30	131.3	14	37	10
60	130	98	36.5	46.5	5	M8	30	150.1	14	37	10

Data sheet

Allocation of planar surface gantry to servo motor for X-/Y-axis

Planar surface gantry	Motor
EXCH-40-...-AB1	EMMS-AS-70-M-LS-RMB
EXCH-40-...-AS1	EMMS-AS-70-M-LS-RM
EXCH-40-...-AB2 ¹⁾	EMMS-AS-100-S-HS-RMB
EXCH-40-...-AS2	EMMS-AS-100-S-HS-RM
EXCH-60-...-AB2	EMMS-AS-100-M-HS-RMB
EXCH-60-...-AS2	EMMS-AS-100-M-HS-RM
EXCH-60-...-AB3 ¹⁾	EMMS-AS-140-S-HV-RMB
EXCH-60-...-AS3	EMMS-AS-140-S-HV-RM

1) Essential when the planar surface gantry is mounted vertically.

Allocation of planar surface gantry to servo motor for Z-axis

Planar surface gantry	Motor
EXCH-40-...-E1	EMMS-AS-40-M-LS-TMB
EXCH-40-...-E2	EMMS-AS-40-M-LS-TMB
EXCH-60-...-E1	EMMS-AS-55-M-LS-TMB
EXCH-60-...-E2	EMMS-AS-55-M-LS-TMB

**Note**

Third-party motors with a driving torque that is too high can damage the planar surface gantry. When selecting the motors, please observe the limits specified in the technical data. During commissioning, the motor brake must be released for safety purposes.

Combinations of motor and motor controller

Planar surface gantry	Order code (→ page 30) for		Motor controller
	Motor type for X-/Y-axis	Attachment component for Z-axis	
EXCH-40-...	AB1, AS1	P1, P2, P3	2x CMMP-AS-C5-3A
		E1, E2	2x CMMP-AS-C5-3A, 1 or 2x CMMP-AS-C2-3A, for front unit (per electric axis)
	AB2, AS2	P1, P2, P3	2x CMMP-AS-C5-11A-P3
		E1, E2	2x CMMP-AS-C5-11A-P3, 1 or 2x CMMP-AS-C2-3A, for front unit (per electric axis)
EXCH-60-...	AB2, AS2	P1, P2, P3, P4	2x CMMP-AS-C5-11A-P3
		E1, E2	2x CMMP-AS-C5-11A-P3, 1 or 2x CMMP-AS-C2-3A, for front unit (per electric axis)
	AB3, AS3	P1, P2, P3, P4	2x CMMP-AS-C5-11A-P3
		E1, E2	2x CMMP-AS-C5-11A-P3, 1 or 2x CMMP-AS-C2-3A, for front unit (per electric axis)

**Note**

Motor controllers must be ordered separately as accessories
→ page 34.
Control system on request.

The "Handling Guide Online" tool can be used to configure the planar surface gantry with other combinations (motor/motor controller).

Ordering data – Modular product system

Ordering table					
Size	40	60	Conditions	Code	Enter code
Module no.	1923050	1939785			
Product type	EXCH series H			EXCH	EXCH
Size	40	60		-...	
Stroke of the X-axis [mm]	200 ... 2000	500 ... 2500			
Stroke of the Y-axis [mm]	200 ... 1000	500 ... 1500			
Guide	Recirculating ball bearing guide			-KF	-KF
Motor type	Servo motor, size 70, with brake	-	[1]	-AB1	
	Servo motor, size 100, with brake		[3]	-AB2	
	-	Servo motor, size 140, with brake	[2] [3]	-AB3	
	Servo motor, size 70	-	[1]	-AS1	
	Servo motor, size 100			-AS2	
	-	Servo motor, size 140	[2]	-AS3	
	Without motor		[4]	-W	
Motor mounting position	Underneath			-B	
	On top			-T	
Energy chain connection side	Left			-L	-L
Attachment components	Without			-T0	
	Electric lifting unit, 100 mm stroke			-E1	
	Electric lifting unit, 200 mm stroke			-E2	
	Pneumatic lifting unit, 50 mm stroke			-P1	
	Pneumatic lifting unit, 100 mm stroke			-P2	
	Pneumatic lifting unit, 150 mm stroke			-P3	
	-	Pneumatic lifting unit, 200 mm stroke			

[1] AB1, AS1 Not in combination with size 60

[2] AB3, AS3 Not in combination with size 40

[3] AB2, AB3 Essential in the case of a vertical mounting position

EXCH-40: AB2, EXCH-60: AB3

[4] W Not in combination with C, CC, CS, C2, B1, B2, B3, B6, B7, B8, S1, S2, B (operator unit)

 **Note**

In combination with characteristic W (without motor), the planar surface gantry EXCH is delivered without coupling housing and without coupling.

Ordering data – Modular product system

Ordering table					
Size	40	60	Conditions	Code	Enter code
Cable length	Without			-	
	With cable length 5 m			-5K	
	With cable length 10 m			-10K	
Mounting kit	With adjusting kit				
	With mounting kit			-P	
Document language	German			-DE	
	English			-EN	
	Spanish			-ES	
	French			-FR	
	Italian			-IT	
	Russian			-RU	
	Chinese			-ZH	

Accessories

Sensor mounting EAPR

For proximity sensors
SIES-V3B and SIES-Q8B
(for sensing the slide position on the X-axis)

Material:
Switch lug: steel
Sensor bracket: wrought aluminium alloy
RoHS-compliant

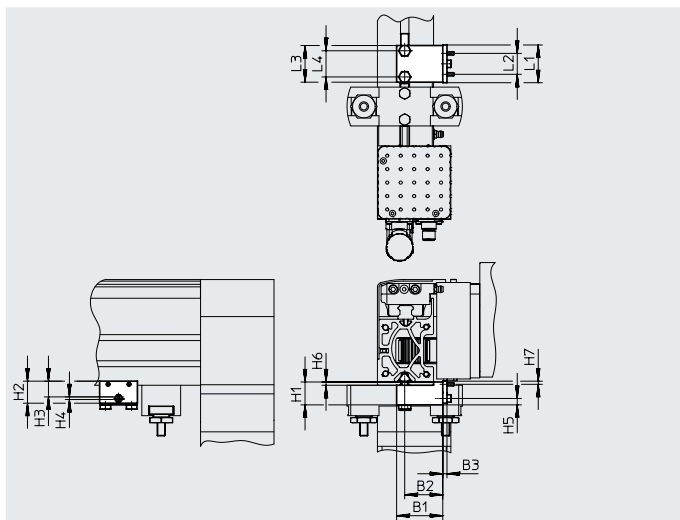

Dimensions and ordering data

For size	B1	B2	B3	H1	H2	H3 ±0.1	H4	H5	H6 -0.1	H7 -0.2
40	44	36.3	4	21.8	21	15	2.5	6.1	3.1	3
60	54	46.3	4	21	21	15	2.5	5.3	2.3	3

For size	L1	L2	L3	L4	Weight [g]	Part no.	Type
40	36	20	35	25	120	2536353	EAPR-E12-40
60	36	20	35	25	150	2478805	EAPR-E12-60

Ordering data

	For size	Description	Part no.	Type
Adjusting kit EADC				
	40	For mounting and aligning the planar surface gantry. The kit is height-adjustable	8029165	EADC-E12-40
	60		8029166	EADC-E12-60
Mounting kit EAHM				
	40	For mounting the planar surface gantry. The kit is not height-adjustable	3489340	EAHM-E12-K-40
	60		3489318	EAHM-E12-K-60

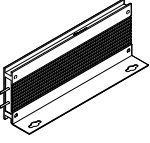
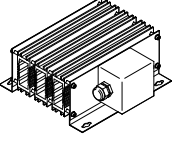

Accessories

Ordering data						
	For type	Resistance value [Ω]	Nominal power [W]	Weight [g]	Part no.	Type
Braking resistor CACR (essential in the case of a vertical mounting position)						
	EXCH-...-B1/B2/B3	50	200	550	2882342	CACR-LE2-50-W500
	EXCH-...-B6/B7/B8	40	800	2400	2882343	CACR-KL2-40-W2000



Permissible proximity sensor for sensing the position of the slide on the Y-axis

Ordering data – Proximity sensor for T-slot, inductive							Data sheets → Internet: sies
	Type of mounting	Electrical connection	Switching output	Cable length [m]	Part no.	Type	
	Insertable in the slot from above, flush with the cylinder profile	Plug M8x1, 3-pin	PNP, N/O contact	0.3	551387	SIES-8M-PS-24V-K-0.3-M8D	

Permissible proximity sensors for sensing the positions on the Z-axis

Ordering data – Proximity sensors for T-slot							Data sheets → Internet: smt
	Type of mounting	Electrical connection	Switching output	Cable length [m]	Part no.	Type	
With mini slide DGSL (magneto-resistive)							
	Insertable in the slot from above, flush with the cylinder profile	Plug M8x1, 3-pin	PNP, N/O contact	0.3	551367	SME-10M-DS-24V-E-0.3-L-M8D	
With mini slide EGSL (inductive)							
	Insertable in the slot from above, flush with the cylinder profile	Plug M8x1, 3-pin	PNP, N/O contact	0.3	551387	SIES-8M-PS-24V-K-0.3-M8D	

Permissible proximity sensors in combination with sensor mounting EAPR-E12

Ordering data – Proximity sensors							Data sheets → Internet: sies
	Type of mounting	Electrical connection	Switching output	Part no.	Type		
N/O contact							
	Screwed on	Plug M8x1, 3-pin	PNP	150491	SIES-V3B-PS-S-L		
N/C contact							
	Screwed on	Cable, 3-wire	NPN	174550	SIES-Q8B-NO-K-L		

Accessories

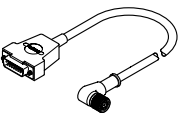
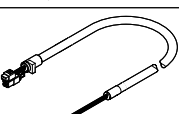
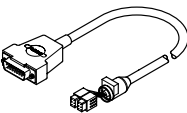
Ordering data – Cables					
		Description	Cable length [m]	Part no.	Type
For X-/Y-axis					
	Motor cable NEBM		5	550310	NEBM-M23G8-E-5-Q9N-LE8
	<ul style="list-style-type: none"> • Min. bending radius: 64 mm • Suitable for energy chains • Ambient temp.: -40 ... +90°C 		10	550311	NEBM-M23G8-E-10-Q9N-LE8
	Encoder cable NEBM		5	550318	NEBM-M12W8-E-5-N-S1G15
	<ul style="list-style-type: none"> • Min. bending radius: 75 mm • Suitable for energy chains • Ambient temp.: -10 ... +80°C 		10	550319	NEBM-M12W8-E-10-N-S1G15
For Z-axis					
	Motor cable NEBM		10	550307	NEBM-T1G8-E-10-Q7N-LE8
	<ul style="list-style-type: none"> • Min. bending radius: 55 mm • Suitable for energy chains • Ambient temp.: -40 ... +90°C 		15	550308	NEBM-T1G8-E-15-Q7N-LE8
	Encoder cable NEBM		10	550315	NEBM-T1G8-E-10-N-S1G15
	<ul style="list-style-type: none"> • Min. bending radius: 75 mm • Suitable for energy chains • Ambient temp.: -10 ... +80°C 		15	550316	NEBM-T1G8-E-15-N-S1G15

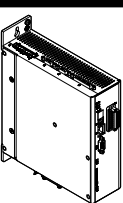
Ordering data – Motor controller							
		For size	Output voltage [V AC]	Nominal output current [A]	Nominal power [VA]	Part no.	Type
	For planar surface gantry						
	40	3x 0 ... 270	5	1000	1622902	CMMP-AS-C5-3A-M0	
	40, 60	3x 0 ... 360	5	3000	1622903	CMMP-AS-C5-11A-P3-M0	
	For attachment components						
	40, 60	3x 0 ... 270	2.5	500	1622901	CMMP-AS-C2-3A-M0	

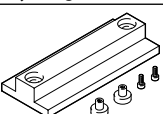
Ordering data					
		For size	Description	Part no.	Type
Adjusting tool EADT					
	40, 60	For aligning and checking the levelness of the planar surface gantry		3197697	EADT-W-E12